

SHAPA

SHAPA TECHNICAL PAPER 13

**A Practical Guide
To
Rotary valves**

A Practical Guide to Rotary Valves

Ian Blackmore - Rota Val Ltd
Professor Mike Bradley – The Wolfson Centre, University of Greenwich

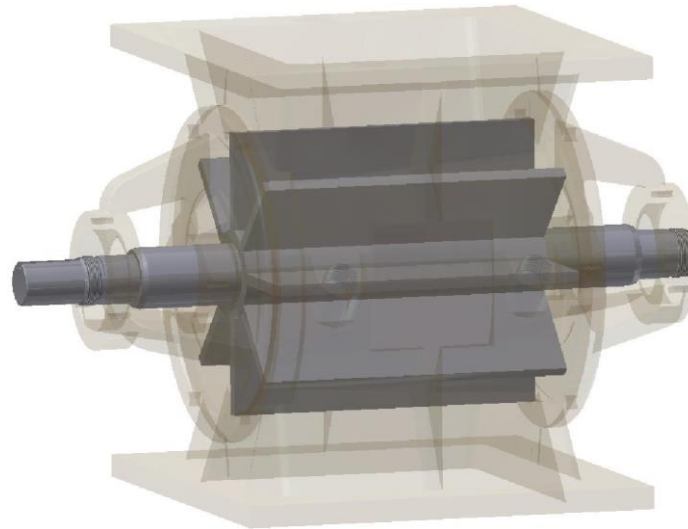

Introduction

Rotary Valves are one of the most common means of feeding pneumatic conveying systems, both pressure and vacuum types. There are many other applications where they are used simply for metering of a controlled feed rate. Given the great numbers of these items in use, it may be tempting to think that the selection of Rotary Valves would be a straightforward and widely understood process. Yet given the number of troubleshooting projects taken on by The Wolfson Centre, where Rotary Valves are involved, clearly this isn't so. Why do so many troubles come from these apparently simple components? This article seeks to explain the apparent mystery surrounding the selection of the right valve for the job, and warn of the pitfalls awaiting the unwary. Commonly thought of as a 'commodity' product it is hoped that with a little understanding of the factors that affect the correct selection of a Rotary Valve, it will be recognized that the choice of type and features to be included from the apparently bewildering variety available is often vital if satisfactory performance for a given duty is to be achieved.

What is a Rotary Valve?

It is a compact mechanical device for continuously discharging bulk powders or granules under gravity flow. By definition it is the simplest of machines having only one moving part (ignoring the drive); a multi-vane Rotor revolving with close clearances in the housing and where the housing has an inlet at the top, and an outlet at the bottom.

Despite its simplicity it offers several functional uses:-

- 1. Control the product flow rate to the required value (fixed or variable)**
- 2. Maintain a gas pressure differential between the inlet & outlet (airlock)**
- 3. Act as an explosion barrier**
- 4. Act as a Flame Barrier**
- 5. Act as a process isolator / barrier**

As well as satisfying any one, or any combination, of these needs the valve also has to overcome any adverse characteristics of the product being handled. To complicate matters further product characteristics can be altered by the duty conditions which are not always stable.

Notwithstanding the above some 60%+ of applications can readily be satisfied from standard components and, if necessary, the inclusion of common additional features. The remainder tend to require specialist input in order to ensure satisfactory performance and service life.

In all cases, technically competent suppliers will examine the duty carefully to ensure that the right unit is offered, and to be sure that any special considerations are identified and provided for.

Limitations:

When designing systems incorporating Rotary Valves, and considering the choice of unit, especially when acting under a pressure differential, it is important to recognise that:

- **A Rotary Valve does not create product flow; it can only pass such product that can fall into it and out of it under gravity.**
- **All Rotary Valves leak air (or gas) when the system is operating (regardless of whether there is a pressure differential or not) and this can affect product flow and system performance, especially where the gas pressure below the valve is the greater.**
- **The faster the rotor speed, the lower and more erratic will be the filling efficiency.**
- **The greater the pressure differential across the Rotor, the less predictable and less stable will be the filling efficiency.**

These factors mean that:-

The performance of a Rotary Valve is affected by the design and performance of the system, and vice versa.

The selection of Valve speed and size is not a precise science and is selected taking into account the various factors that may negatively affect its performance from the theoretical maximum.

Selection Criteria

The selection of final design and features evolves through four distinct areas of consideration:-

1. The basic performance requirement:

This identifies the size of the unit and considers the throughput rate, product density, flow characteristics and any factors that may influence these such as valve throat size, opposing air/gas leakage etc.

There are various factors that affect the choice of valve size and speed and which are collectively assessed to give an expected "Filling Efficiency". Because of the vagaries of product flow and system conditions/performance it is normal to run the valve at a speed that allows time to mitigate some of these factors. By its nature the final speed, and therefore valve size selected, is based on calculation, empirical data and keen judgement based on experience and knowledge of the product being handled.

A key factor is Rotor Speed; based on calculation and supported by empirical data it is normally accepted that a Rotor tip speed of 40 metres / minute is about the maximum; thereafter an increase in speed results in a decrease in throughput. This is based on a reasonably free flowing product having to accelerate from a standstill under gravity immediately at the valve inlet. I.e. the valve running in a flooded condition. This figure may be lower if the product has a low bulk density and / or if there is a significant pressure differential giving rise to airflow opposing product flow. Equally the figure may be higher if the valve is fed under cascade flow conditions such as is achieved from screw feeders, belt feeders, weighers, etc.

Notwithstanding this great care needs to be taken in operating valves at this maximum as the filling efficiency will be affected by the vagaries of system performance and can result in erratic and less predictable throughput results, especially with the smaller valve sizes.

In theory it is therefore possible to run a valve with a 150mm (6") diameter Rotor at 85rpm to achieve a tip speed of 40 mtrs/min, whereas a 1000mm (39.3") diameter Rotor will have a limit of only 12.7 rpm.

Because of other influences especially throat size it is unlikely that reliable results could be achieved with the smaller sizes at the higher speeds, therefore it is normal practice to select a valve size that gives rotor speeds below 25rpm for Valves with Rotor Diameters up to 300mm; thereafter it becomes progressively safer to run closer to the 40 mtrs/minute tip speed.

2. Product Physical Characteristics:-

These usually dictate the detailed design and construction of the individual components, and knowledge of the handling characteristics within the valve under the duty conditions is essential for their final selection. This point is emphasised as many products that are considered easy to handle in other equipment can become difficult when exposed to conditions within the valve. Examples are materials that become abrasive when entrained by high velocity leakage air through the close operating clearances within the valve, causing erosion of the valve surfaces. (In such cases the lower the Pressure Differential the better). Other materials can form a hard 'glazed' build up on the working surfaces causing excessive torque requirements.

Rotary Valves also have to be able to cope with the full range of challenging characteristics such as sticky, abrasive, corrosive, biologically sensitive, cohesive, toxic, flammable, speed sensitive, explosive, non-friable etc., and more often than not a combination of some of these. It is important that the design of the Valves can accommodate as wide a range of alternative features as possible.

3. System / Duty Requirements

This will identify the primary Valve configuration and materials of construction and take into account the following:

Physical Installation Details

This identifies preferred Flange Details, whether square or round and hole drillings. Some manufacturers include composite Square / Round flanges which are useful where the inlet is different to the outlet, but such an arrangement is usually confined to 'budget' Valves.

The final choices of Housing and End Covers, along with the type of drive arrangement and whether an inbuilt venting arrangement is used, will usually be made at this point (see below).

Pressure Differential

This is always a vital consideration as the higher the differential the greater the leakage of air / gas, and can have a great bearing on the final choice of valve size and features. High upward leakage can significantly reduce material flow by both reducing the bulk density through fluidisation and by physically opposing flow.

High leakage can enhance the abrasiveness of some hard fine particle products, transfer moisture and create unstable flow conditions. (See section on Venting below).

Operating Clearances and Temperature

In order to provide for manufacturing tolerances and to minimise drive torque requirements all valves have running clearances between the Rotor and Housing. The escape of gas through these clearances is the major component of leakage; therefore they need to be kept as small as practical. A good quality Cast Iron / Carbon Steel valve under ambient temperature conditions designed for minimal leakage will have a nominal clearance of 0.13mm. This is increased to 0.18mm for all Stainless Steel construction to minimise the risk of galling / seizing should the Rotor make contact with the Housing under extreme load conditions or due to bearing failure etc.

Where the operating temperature exceeds ambient by more than 30°C then the clearances start to need to be increased as the Rotor will expand at a different rate than the Housing during warm-up either at the start or during temperature fluctuations; this is because the Rotor is a lighter component and is not subject to surface heat loss unlike the Housing. The degree of increase depends on the individual duty conditions and it is important to allow for the greater leakage that will occur.

4. Individual Industry & individual Customer Needs

These can be some of the most demanding aspects for a supplier, requiring the valve manufacturer to offer flexibility in both its manufacturing and commercial capability to satisfy differing customer needs.

As an example, those in say the quarrying industry generally are not worried about most aspects of the valve supply providing it performs to spec and is durable, whereas at the other extreme the food and in particular the pharmaceutical industry are necessarily demanding in the detail design, surface finish and other features to be included (some occasionally unique to their needs), manufacture (GMP) and validation of the supply, which must be backed up by extensive documentation, certification and where appropriate, Factory Acceptance Tests, followed by post delivery tests prior to final acceptance.

5. Effects of Legislation

Apart from the normal Machinery Directive, Rotary Valves can fall under the Pressure Equipment Directive (PED), and ATEX 94/9/EC Directive for potentially explosive atmospheres.

PED tends to affect the larger valves i.e. 450mm and above because of the pressure / volume relationship; this generally is not a problem as the natural robustness of the standard design is more than adequate and is therefore mainly a documentary procedural requirement only, although hydrostatic testing is a requirement on units whose size falls within the scope of PED to validate the integrity of the components.

The EC ATEX Directive 94/9/EC however can affect the design and construction and this is outlined in the Appendix attached.

Typical Design / Feature Considerations

Housing Body & End Covers

Generally the manufacture of Rotary Valves follows good general precision engineering practices with materials of construction selected according to the duty needs or occasionally customer preferences. The Housing is normally of cast construction for rigidity and cost, however fabrications are occasionally used for non standard configurations and 'one-off' large valves that cannot be satisfied from cast patterns.

Fabrications or machined from solid are increasingly used for critical pharmaceutical use where guaranteed flaw free validation is essential.

Body Design

The wide variety of different Body configurations offered by different competitors and simple appearance belie the fact that the detail design is an integral part of the performance of Rotary Valves. In an ideal world the body would be designed to suit each application but as that is not practical they are a compromise in specific areas to encompass as many application needs as possible.

The inlet throat design can be critical as it is a very dynamic area and can influence the product flow into the Rotor Pocket, drive torque levels and the effective dispersion of leakage air. The latter in particular can influence rate and consistency

of product flow and can also result in the difference between mass flow and core flow when sited under a head of material with some products.

Inline Inlets



This is the ‘classic’ configuration and is practical for most applications

Offset Inlets



This configuration is set to ensure that the Valve can never achieve 100% filling efficiency and is required to minimise the incident of product shearing. Some manufactures provide a ‘plough’ profile in the inlet design to disperse product into the voids that naturally occur in the Rotor Pockets when filling, away from the point of shear.

Housing End Covers

These fall into two categories; those with inboard mounted bearings and those mounted on outrigger extensions. The use of inboard bearings are generally confined to low cost, low duty valves and are typically offered for low pressure differential applications, typically filter / cyclone and general discharge duties, where the product does not exhibit difficult handling characteristics.

The use of outboard mounting is often believed to be to protect the Bearings from direct product contamination however there is only limited benefit in this regard as any seal failure usually results in product ‘jetting’ along the shaft directly at the Bearing.

The primary reason for outboard mounting is to provide space for accommodating a wide range of alternative Shaft Sealing arrangements. There is the added benefit for more demanding applications as they are inherently larger to accommodate larger Rotor shaft diameters necessary to limit Rotor deflection under high operating loads.

Air purge connections can be included if necessary to provide an injection of air either sequentially pulsed or continuously to dislodge products at the valve outlet that

tend to ‘hang’ in the Rotor Pockets. These connections may also be used to pressurise the void that exists between the End Cover and End Discs when using Closed Rotors to prevent product entry.

Blowing Seals



This is the common designation for Rotary Valves that are designed for direct connection into Pneumatic Conveying Blowlines. They can be designed for true blow through of the Rotor Pocket , often referred to as direct purge, or can be arranged to have an entrainment trough whereby the conveying air passes partly along the trough and partly through the Rotor and referred to as Semi-Direct Purge.

The Direct Purge design is the most efficient and covers a wider range of materials however it suffers from severely restricting the drive arrangements that can be fitted, due to the closeness of the pipe connections to the Rotor Shaft, and consequently the Semi-Direct is the more common.

Entrainment Boxes

For applications where the Blowing Seal is not suitable then normal Drop-Through Rotary Valves are used with a separate Transition box to connect to the Blowline. Such connections are common as they can be adapted for different pipe sizes and are preferred for some products and conditions anyway.

There are many ‘fanciful’ designs offered that look well engineered and look ‘the part’ but research some years ago by the Wolfson Centre (Reference Steven Kessel) identified that simple straight sided designs tapering down to the pipe are effective for most applications and the deeper the better, although where headroom is a problem simple modifications to the standard design can help.

ROTORS

Rotors are the most variable component and come in a wide range of alternative features; Most Rotors are fabricated to give manufacturing flexibility to incorporate alternative features. Some manufactures use castings for cheapness but their use is very limiting.

There are two fundamental types:-

Open Vane

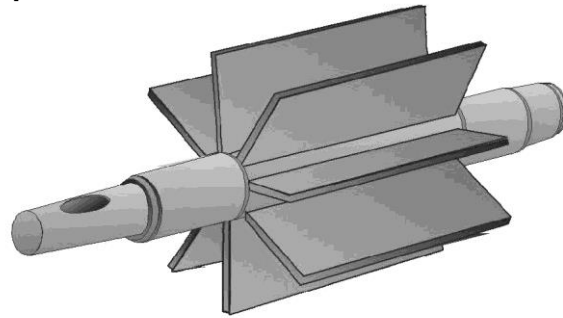

Closed Vane

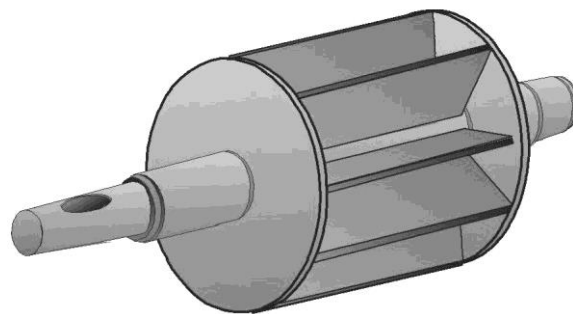

Whenever possible the open type is to be preferred as it performs better, is much more able to be adapted with special features, is more tolerant to changes in the product and can be purged if necessary. Closed types are not suitable for use in Blowing Seals

The closed type should only be employed when aspects of the product and or duty demand it. Problems with this type include product ingressing into the void between the End Cover and Rotor disc, high wear in the Bore where there is close proximity with the Rotor Disc, and significantly increased risk of product 'hang-up' in the pockets. Unfortunately the lower cost for producing this type, and ease of assembly, means it is offered by some manufactures for competitive reasons regardless of suitability. Closed type give the Vanes more support and rigidity and are preferred when heavy product shearing is unavoidable, or when squealing tends to occur as a consequence of product build-up on the internal surface of the housing.

Typically rotors have around 8 pockets which provide a minimum of 4 vanes (2 per side) sealing at any one time. More vanes increase the sealing capability but significantly reduce the filling efficiency.

SOME COMMON ROTOR FEATURES

The basic Rotor is normally a fabricated Open Type with fixed vanes. Detail designs differ between manufacturers but will be mounted such that it is held centrally so that running clearances are not compromised between the Rotor and End Cover faces.

Replaceable Blades

These are by nature adjustable on assembly but should not be considered as being supplied to be able to adjust for wear as wear is never even, neither is it confined to the blades. It is however an economic way of introducing alternative materials of construction that may be required to satisfy the duty. Common examples include

- *Hardened steel; or alloy steel; or hard faced:** for abrasion resistance,
 - Scraper:** to control Product build-up on the Housing bore and End Cover faces when necessary,
 - Flexible:** (usually polyurethane or natural rubber) for fibrous or products containing large non friable particles
 - Plastic:** Product compatible or non-stick
 - *Bronze or bronze tipped:** for ultra close clearances
- Etc.**

**(If Replaceable Blades are not practical or not permissible then Fixed Vane Rotors can have their tips Hard or Bronze faced).*

Because gravity is relied on to discharge product from the Rotor pockets provision has to be made to resist the tendency of sticky material to hang-up. In this case the Rotor is normally manufactured with 'Scalloped' pockets; this may be enhanced by coating from one of a range of non-stick coatings such as PTFE, 'Zylon' etc. Unfortunately such coatings are subject to wear and if contamination is an issue then manufacturing the Rotor in Stainless Steel and polishing the surfaces is a suitable but more expensive alternative.

In extreme cases the product may need to be encouraged to discharge through air purging where pulses of air are injected laterally at a suitable point at the End Covers.

Helical Vanes/ Staggered Pockets

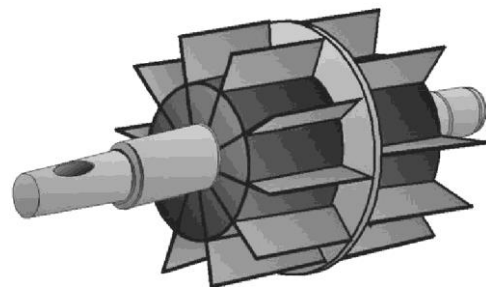
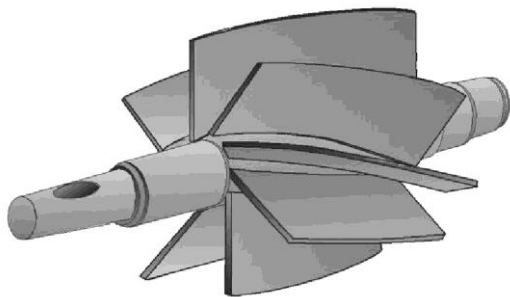

These are provided to try to smooth-out the discharge from the valve when necessary. In practice a standard Rotor will discharge the bulk of the product within 10% of pocket exposure, giving rise to a pulsed output; not normally a problem but where it is, then this type of configuration can help. It is only suitable for fixed vane Rotors however.

Shaft Sealing

Because of the dusty and dry shaft application of Powder handling, providing a durable and dust tight seal on a rotating shaft can be difficult even when there is not a pressure differential. Consequently there is a wide range of seal types and configurations

Felt	Generally limited to very low cost low duty applications
Lip Seals	In standard form can be used in place of Felt Seals or in support of Felt seals. Specialised Lip Seals designed and manufactured in FDA approved materials are used in high end food and Pharmaceutical Applications.
Gland Packing	The most commonly used Sealing arrangement due to low cost, versatility and ease of replacement 'in situ'. Packing material is made from a variety of woven fibres and impregnated with a lubricant suitable for the application; thus can be made suitable for general applications, food and with the use of Carbon Fibres capable of applications up to 1000°C+
Pressurised Seals	Double Seal arrangement with void in between pressurised above the max internal working pressure of the Rotary Valve, designed to leak air or gas inwardly in the event of Seal failure. Also any seal failure can be detected by incorporating pressure or flow sensors.
'Lantern Ring' Air purge Seals	Provides positive inward flow of air or gas to physically keep product from entering the Seal area. Particularly recommended for fine abrasive products or products with 'searching' characteristics. Failure to maintain air supply when running can block air passages.
Labyrinth 'Scroll' Air Purge Seals	Same principle as the Lantern Ring Type except that the purge air flows through a 'scrolled' channel which also mechanically 'screws' any ingressing product back into the Valve. This type is particularly effective with fine highly abrasive products.

Mechanical Seals	Suitable for most products particularly fine abrasive – normally used with air purge - Expensive
CIP Seals	Provides for wet cleaning and drying in place; specifically for Food & Pharmaceutical use. Design is integral with the end Cover and therefore normally only provided with bespoke Valves.

***Air purge seals can also employed to provide cooling air to the critical root of the Rotor shaft to prevent plasticizing of some polymers and foodstuffs as a result of heat generation from particle friction within the product.**

Bearings

In most cases bearings are of the sealed-for-life deep groove ball race types mounted directly in the End Cover. Standard units being grease filled and sealed using neoprene or similar integral seals are suitable for up to 200°C temperature. Use of different materials, shields and lubricants extend temperature capability up to 800°C. Thereafter special plain bearings are used for temperatures above 800°C.

The size of the bearings fitted is generally dictated by the physical size of the Rotor shaft, rather than any direct relationship with load and speed factors, and as a result are oversized for the pure duty and consequently in clean conditions have an almost infinite service life. They are however vulnerable to product contamination and it is important that Shaft seals are checked and maintained regularly.

Mounting Bearings directly in the End Cover bearing supports provides for good control over critical concentricity. Some manufacturers use cartridge or pillow block bearings but these lack the finesse needed for close clearance high performance valves. On very large valves where on-site servicing is difficult cartridge bearing assemblies may be fitted out of necessity avoiding the need to remove the heavy End Covers to effect bearing replacement.

Drive Arrangements

With the exception of Hydraulic Motors all Rotary Valves are driven via a reduction gearbox usually with power provided by an integrally mounted electric induction motor. These may be direct mounted to the Rotor shaft or side mounted driving the Rotor through Chain and sprocket. The latter is the most popular for two reasons

- 1. It provides easy speed change on site to calibrate the throughput, although this is somewhat limited on the smaller sizes of Blowing Seals due to the limited space for the Rotor Sprocket.**
- 2. By rating the chain size against its breaking strain it can be used as a crude safety overload protection. It is usual for customers not to fit a positive overload protection device as it can be subject to abuse by local operators and is a costly extra.**

Valves designed for regular dismantling for internal cleaning tend to be fitted with direct drives to facilitate easy withdraw of both End Covers.

Accessories

Common additions to Rotary Valves include

- Positive Overload protection (shear pin or proprietary torque limiting devices)
- Non Rotation detection
- Speed monitors
- Safety switches on Easy Clean valves
- Variable speed controls
- Pressure regulators and flow meters for Air Purge Seals
- Rotor Pocket purging equipment

A recent development has been the introduction of Rotor Contact detection such as the 'RotaSafe RM' unit which provides instant intrinsically safe detection the moment there is contact between the Rotor and Housing, automatically shutting off power to the drive motor. This provides significant benefits to the end user:-

- Protects the valve from internal damage
- Eliminates contamination in the product from metal shedding
- Prevents start-up if Valve reassembled incorrectly.
- Detects bearing failure
- Protects ATEX 'autonomous safety system' certification (any internal damage to the critical working surfaces immediately renders the Valve 'unsafe')

Food & Pharmaceutical Applications

Fortunately, nearly all food and pharmaceutical product characteristics are easily managed, and the basic design of the Valve in this regard can remain relatively simple without compromising hygiene and ease of use when appropriate. Common product characteristics, including being sticky, cohesive, corrosive, tendency to 'build-up' on the swept surfaces etc., are compatible with the use of Stainless Steel with polished or non-stick coated surfaces.

As abrasion is not normally an issue, relieved Rotor Vane tips are normally incorporated as standard; this minimises the drive torque requirements should the product tend to build-up on the surfaces.

Given that the mechanics of handling the products do not normally present any great difficulties, then design considerations relate primarily to the valve construction to meet the standards of hygiene needs, operator facilities environmental and End User needs and preferences.

Most food and pharmaceutical chemicals and ingredients are potentially explosive in dust form and will be subject to the ATEX Directive. Whenever the valve is required to act as a Flame Containment device, regardless of pressure condition or external environment, then it automatically becomes categorised as an 'Autonomous Safety System' requiring certification of a Notified Body who must approve the Technical File and manufacturing procedures. (See Appendix)

Food Applications

Most foodstuffs are biodegradable however some do not pose a hygiene risk as they represent or contain a sterilising or preserving agent; such products include sugar, salt, chocolate etc., and standard valve construction only is required. Other products

that have a long storage life, providing they remain dry, also do not require special features especially if they will be further processed by cooking. Flour and rice are typical examples. In all these cases, unless there is corrosion risk, Cast Iron / Carbon steel would suffice however most users now require Stainless Steel, as a matter of good practice

Std St. St. Valve + Polished Internal Surfaces



Food products that are subject to bio-degradation require careful consideration depending on the degree of sensitivity. St.St. construction is essential, as is the need for the construction to be free from cracks and crevices where residual product can collect, decompose and contaminate fresh product. Welds and internal surfaces are usually polished to Ra0.8 or better and construction is to USDA guidelines utilising FDA approved materials. A common feature requirement is easy access to the valve internals for cleaning. For low sensitivity materials requiring only infrequent cleaning simple access, quick release fittings only may be considered.

'Easy-Clean' Valve with Quick Release Rotor



This is a low cost option but suffers from the disadvantage that components are easily damaged, and is not particularly operator friendly, requiring risk assessment under the Safe Handling regulations especially for the larger sizes. Weight and sharp edges are particular hazards.

High sensitivity materials such as baby food products, high fat milk powder, pharmaceuticals etc., require a higher degree of contact surface finish and integrity, often polished to a 'mirror' finish. The need for regular frequent cleaning has resulted in the development of support rails to facilitate safe and easy extraction with access to both ends of the Valve without the need for additional handling equipment.

'Fast Clean' Valve with Support Rails



Pharmaceutical Applications

The Pharma industry is understandably extremely demanding in all aspects of its dealings, and the understanding of its needs along with the ability to satisfy them is essential. While many applications are comparable to those for food, construction must be to current good manufacturing practice (cGMP) of the Pharma industry along with full validation and documentary support.

Active pharmaceutical chemicals are by their nature normally toxic to a greater or lesser extent, and purity of production is essential; this determines several essentials in the valve design:

- **Manufacture of the components and design of the final assembly must be to the highest standards possible or at least to that set out in the User Requirement Specification.**
- **All internal contact surfaces must be capable of being cleaned ideally through Clean-in-Place (CIP) procedures; this includes shaft sealing.**
- **Opportunity for product trapment within the valve must be eliminated.**
- **Operator Exposure Levels (OEL) to be kept within acceptable limits.**
- **Construction integrity (including surface finish) must be maintained throughout the operational service of the valve.**
- **All aspects must be verified by measurement or test.**
- **Explosion risk is normally secured through full containment and Valves must be capable of passing Explosion and Flame containment testing.**
Flame containment capability requires close operating clearances and FAT inspection will require hot water flush testing (normally 85°C at 20 °C ambient)) to prove that differential expansion during CIP does not cause contact between the Rotor and Valve Body components.

Typical features to satisfy these requirements include

- **Manufacture of all components from solid material, or fabricated using approved coded welding. This eliminates the use of castings and the risk of pin-hole porosity and contaminates inclusions.**

Fabrication allows for inclusion of quick release 'pharmaceutical' standard flange connections if required.

Special Pharmaceutical Valve Form mounting in an Isolator Box



- **Surface finishes in contact with the product are normally R_a 0.08 or better and are electro polished primarily to minimise the build-up of surface Pathogens. General external surface finishes R_a 0.5**
- **Precision manufacture, with features to ensure no contact between rotor and valve bore on extraction.**
- **Seal design to FDA standards with care taken to eliminate material 'shedding'**
- **Design can allow operation and maintenance within an Isolator Enclosure (Glove box).**
- **All surfaces self draining.**
- **Shaft Seals designed for CIP and drying in place.**
- **Bearings protected in sealed housings.**

Where Operator Exposure Levels need to be kept critically low then it is likely that the Rotary Valve will be located in an Isolator enclosure. This presents additional design challenges as the Valve will need to be operated via gloved access without the use of tools. Also it is desirable to minimise the number of components so the use of anti-galling materials to eliminate washers etc., is necessary. Also the design must provide for the easy cleaning of both the external as well as the internal surfaces. Design must also provide for e easy extraction of Rotor / End Cover assembly (which can weigh up to 350kgs) by an operator at arms length at right angles to the movement.

Designing Rotary Valves for Food or Pharmaceutical normally requires good understanding of all aspects, and close co-operation with the Customer / End User is usually important if the correct Valve and features are to be incorporated and satisfaction assured.

Dealing with abrasive products

Rotary Valves can be subjected to two types of abrasion:-

- 1. Simple mechanical attrition from larger hard particles and fibrous materials becoming trapped in the running clearances – in this case there are three approaches :-**
 - **Hardfacing the internal surfaces using plasma sprayed Ceramics such as Tungsten Carbide or electro deposited materials such as Hard Chrome, Nickel etc. The actual choice is dependant on the product and conditions. Such Coatings are relatively thin and once breached are ineffective so are only suitable for moderately aggressive products.**
 - **Fitting the Valve with replaceable internal contact components. This has the advantage of offering a much longer service life due to the greater thickness of component hardness along with the ability to be refurbished on site using new replaceable components.**
 - **Use of all ceramic linings in the Housing and Rotor Components. This is the best construction in terms of abrasion resistance but suffers from being extremely expensive and needing to be replaced in its entirety once worn.**
- 2. Velocity erosion from fine abrasive powders drawn through the clearances by leakage air when operating under higher pressure differentials. This is an issue primarily when the valve is operating under high pressure differentials, typically above 250mbar, when velocities can reach as high as 400mtrs/sec. in this case hard-faced valves are rarely suitable.**

Wear through High Velocity Erosion



Minimising risk of Product damage in the Valve

On average some 5% of granular products entering the valve will be subject to shearing between the Rotor Tip and Inlet Throat; where this must be reduced then a reduction to around 1% can be achieved using the Off-set Inlet design (See above) or by fitting an inlet baffle to keep product away from the point of shear.

In either case shearing cannot be totally eliminated. Where there is a zero tolerance on product damage or where the product is unshearable then the only option is to fit two valves in tandem whereby the top unit is fitted with a reduced capacity Rotor with clearances set to be greater than the max particle size; this unit then discharges a set amount of product in phase with the lower Valve Rotor Pockets, thus ensuring the lower valve Rotor, functioning as the primary Rotary Valve will then never be full to the point of shear. Such an assembly does take up twice the headroom and is known as a ‘Metering / Sealing Assembly’.

Air Leakage and Performance

As mentioned above all Rotary Valves ‘leak’ air (or gas) even where there is no pressure differential as even the product entering the valve displaces air into the inlet area. This is significantly added to when operating under a pressure differential due to losses past the operating clearances and carry-over of pockets of high pressure decompressing into the inlet. The total of such losses are normally referred to as ‘leakage’ and given a single quantity value.

There are many factors that affect the rate of leakage and the ratio of the elements that make up the total and all are affected by the system conditions prevailing at any given time. Detailed analysis and understanding of leakage rates is a subject in its own right for another occasion. In practical terms most manufactures only offer leakage charts based on tests measuring leakage past valves in a static product free condition. Because the presence of product has a mitigating effect on leakage, known as the ‘Blocking Factor’, the manufacture’s published rates are seen as having adequate contingency for providing allowances for sizing blowers, fans etc. Where leakage rates are considered critical then better analysis will be necessary taking into account all aspects of the duty conditions.

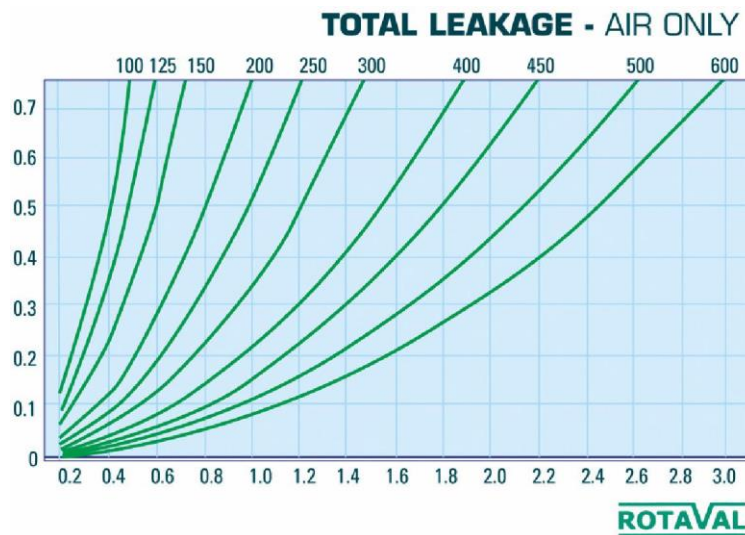

What is important is that upward leakage can have a significant effect on the system performance either positively or negatively especially where the valve is operating in a flooded condition.

The upward flow can reduce throughput by opposing product flow as well as aerating the product and reducing its bulk density. Allowance for this must be made when sizing the Rotary Valve. This is progressively less of a problem as valve sizes increase as the larger throat sizes make for better dispersion of leakage air. Valves

should also be fitted direct to the outlet of any hopper so that leakage air can disperse easily as shown in the diagram

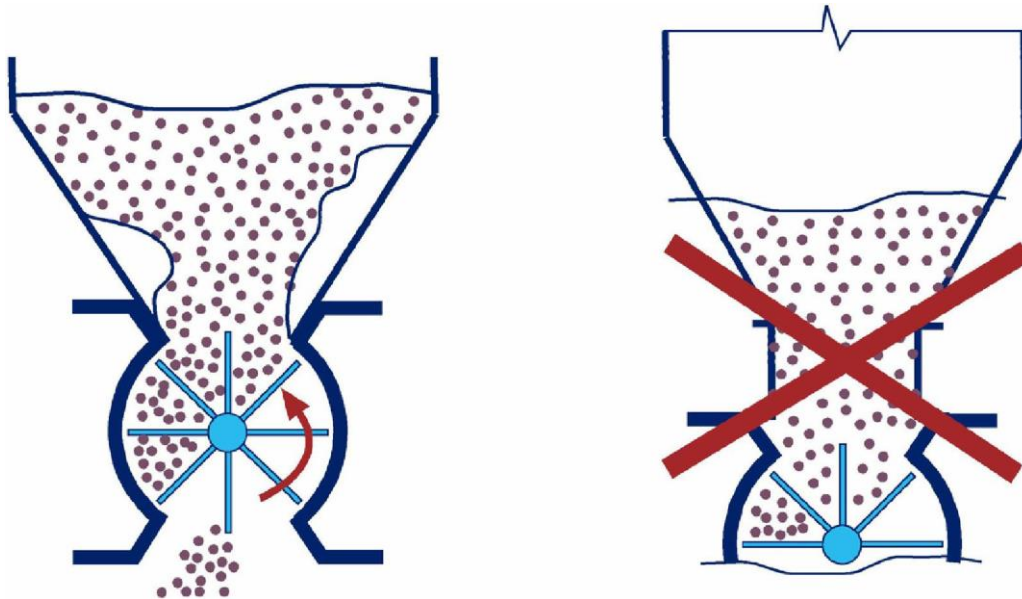

This is less of a problem when the valve is not controlling the throughput but care needs to be taken if the conditions could result in flood feeding at any time.

Venting

Where the upward flow of air will cause unacceptable flow problems then venting the inlet throat will be necessary. Venting is the responsibility of the system designer as it will need to be allowed for within the equipment feeding the valve. As it is usually difficult to provide venting retrospectively the decision whether to vent or not needs to be considered at the outset. Some manufacturers can offer valves with built-in vent dividers in the throat which is more effective than fabrications and simplifies installation as well as valve removal for maintenance purposes.

While some systems engineers design-in venting on every installation whenever there is a significant upward pressure differential, this will not always be good practice as venting can be disadvantageous for several reasons:-

1. Unvented leakage air can help product flow by fluidising some products and not only will a vent remove that advantage but will add a further physical restriction in the throat. The consequence of this is that often unnecessary means of creating product flow need to be added.
2. Where the valve is handling potentially abrasive products under flood conditions the presence of a head of product above the valve will partially suppress the leakage through the valve; the degree of suppression being a combination of height and permeability of the product, the pressure differential and the bulk density of the product. It is not unusual to set a low level control in a high position in the feed vessel to use this to eliminate wear within the Valve.
3. A badly designed vent will compromise system and valve performance.

In many cases venting is simply unnecessary and only adds cost and aggravates the ability to clean equipment particularly where hygiene or product contamination is an issue.

Whether or not to vent and if so the type of venting applied should always be a matter of careful consideration.

Feeding Pneumatic Conveying Systems

Feeding positive pressure pneumatic conveying system represents around 50% of valve applications. In general performance terms, pneumatic conveying duties are potentially the more problematic of Rotary Valve applications. This is because the performance (throughput) of the valve is usually affected by the pressure differential; however the pressure differential is almost invariably a consequence of line loading (throughput) at any given time. Consequently it is very easy to get cyclic and erratic overall performance if there are weaknesses of design and or construction within the system as a whole. As the Valve is sited at the interface between the inlet feed system and the conveying system, poor throughput or high wear within the valve is often blamed on it. While this might be the case if it has been incorrectly specified, more often than not the cause and remedy lie elsewhere.

Summary

In many cases Rotary Valves can be treated as a commodity product and many manufacturers produce and sell them as such offering standard units from stock. Unless prior experience dictates otherwise all applications should be carefully vetted and the Valve specification chosen accordingly. Given that this is done then there are very few products and applications that cannot be satisfied with good economic benefit. Finally it should be noted that where Valve have to incorporate several less common features then their delivery lead time can be very extended and should be considered at an early stage in most projects.



ATEX 94/9/EC & Rotary Valves

EC ATEX 94/9/EC Directive, and its requirements has imposed on suppliers a responsibility to ensure the integrity of supply is guaranteed and meets defined standards; this has both procedural and design consequences depending on the category of use.

Use of Rotary Valves for Explosion / Flame Containment (Category 1)

The ATEX Directive mandates that if there is a risk of an explosion inside equipment then, in the event of an explosion, there is no risk of transferring ignition to any external zoned atmosphere. In this case Rotary Valves can play a vital part of the safety system by providing an explosion and flame containment barrier; in fact it is not unusual for this to be the only reason for including Rotary Valves in the system. In this case ATEX specifies that the Valve be classified as an 'Autonomous Protective System'

This requires that the valve must be approved by a Notified Body, in the same way as for all Zone 20 Category 1 equipment approval, along with some additional requirements; therefore:-

- **Each valve must be accompanied by an EC - Type Examination Certificate issued by an approved Notified Body**

NOTE: Explosion / Flame Containment Certificate issued by a Test house does not satisfy ATEX as it does not prove the material or manufacturing integrity of the individual Valve supplied

- **The Notified Body (not the manufacturer) is responsible for having tests conducted to prove the valves effectiveness for purpose.**
- **The Notified Body Certificate will identify any limits for use i.e. Class of dusts, internal clearances, Vane thickness, pressure limits etc.**
- **Hydrostatic pressure testing of each valve is required as part of the production procedures to prove the integrity of the individual components used. This is especially important when using castings.**
- **The manufacturer's Notified Body must have sight of the technical files and approve them.**
- **The manufacturer must maintain an approved Quality Assurance & Manufacturing system, which is audited by the Notified Body.**
- **Some limited use of replaceable components may be allowed such as Scraper Blades, Knife Blades etc but must be supported by an adequate number of Fixed Vanes that will maintain the containment capability of the valve. Any such inclusions must be approved and certified by the Notified Body.**
- **Regular checking by the end user, in accordance with the IOM's, to ensure clearances stay within the certified limits; this is particularly important when handling a product with an abrasive characteristic.**
-
- **Care on application when dealing with elevated temperatures that the clearances of the valve when cold do not exceed the Certified limits.**

Valves installed in Zone 21 & 22 Dust (Categories 2 & 3)

In general Rotary Valves do not present an ignition risk providing care is taken on materials of construction and Rotor tip speed does not exceed 1mtr/sec. Virtually all applications result in speeds below this but care must be taken with variable speed drives to be sure that the valve cannot inadvertently be speeded-up above the safe figure. Manufacturers have to carry out their own risk assessment, establish technical files, Installation, Operation & Maintenance Instructions etc that satisfy the directive. Responsibility for this and the correct marking on the valves rests with the manufacturer.

Valves installed in Zone 20 External Atmosphere

The basic valve does not pose a hazard although drive motors must be mounted external to the atmosphere, as must any other equipment that cannot or do not carry a certificate for zone 20.

All zone 20 equipment has to be certified by a Notified Body who examine and approve the manufacturer's design, technical file, Installation, Operation & Maintenance Instructions, manufacturing procedures and all associated activities to ensure the suitability and integrity of the final supply.

Internal Atmospheres (When valve is not used as an Autonomous Safety System)

Any zoning of internal atmospheres will almost invariably be to Zone 20 regardless of any safety systems that may limit / suppress explosion pressures.

In such cases an EC Type Examination Certificate will be required to allow for use by confirming that the valve does not provide an ignition source and that it is capable of withstanding any explosion pressure that may be present. In the case of the latter, and where such pressure is greater than 2 barg, hydrostatic testing to an agreed level determined by component material is all that is normally required. As the valve is not to be used for Flame Containment then use of replaceable / adjustable Blades etc is normally allowed.

NOTE:- -----

The above is for guidance only – Responsibility for conforming to current legislation and practices rests with the individual manufacturer.