

• ROTARY VALVES & AIRLOCKS •

INTRODUCTION

The prime function of a rotary valve is to regulate the flow from one chamber to another while maintaining a good airlock condition. The product is mainly in dry powder or granular form.

In the dust filtration field good airlocks are essential on cyclone and bag filter applications in order that the manufacturer's quoted high dust collection efficiencies can be maintained. Airlocks are also important in the pneumatic conveying industry, where product is regulated into a high pressure conveying line while minimising air leakage.

With Rotolok there are no double standards, all our standard valves are precision machined for close tolerances and minimal eccentricities. Pressure differentials to 20psi and temperatures to 400° C.

We have made specials to handle temperatures covering 1200°C and pressures to 350psi.

SPECIFICATION

Bodies

Cast Iron, Stainless Steel or Aluminium precision bored.

End Covers

Cast Iron, Stainless Steel or Aluminium spigot located in body for concentricity.

Rotor

Fabricated Mild or Stainless Steel.

Bearings

Sealed-for -life-ball type rigged outboard or high temperature above 250° C.

Shaft Seal

Gland type with PTFE packing.

Drive

TEFC geared motor unit side wall mounted to valve body and complete with taper lock sprockets chain drive all in an enclosed guard.

STANDARD FEATURES

- Maximum number of blades in contact with body at one time without affecting throughput.
- Good throat opening at valve entry allowing high pocket filling efficiency.
- Minimum clearance at rotor tips and sides with body.
- Robust body adequately stiffened to prevent distortion.
- Heavy shaft diameters minimising deflection.
- Outboard bearings for non-contamination.
- Packing gland type seals.
- Maximising valve speed to 25 rpm - prolonging life, ensuring good throughput.
- Precision machining of components.

All add up to Rotolok standards.

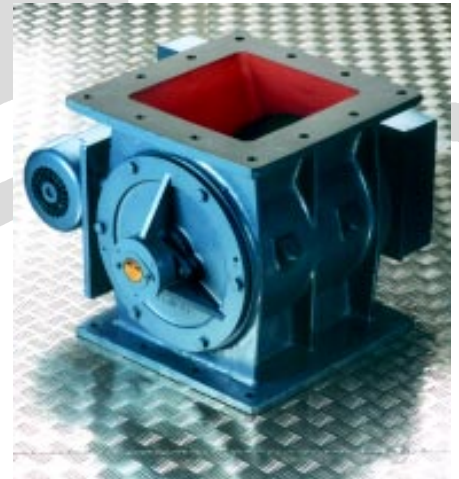

Square Rotary Valve

OPTIONS

- Quick Release Rotors
- Direct Coupled Drives
- Air Purge Glands
- Body Vents
- Vent Boxes
- Dropout Boxes
- V.S. Drives
- Speed Switches
- Flameproof Motors
- Shear Plate Deflectors
- Electroless Nickel Plating
- Hard Chrome Internals etc.

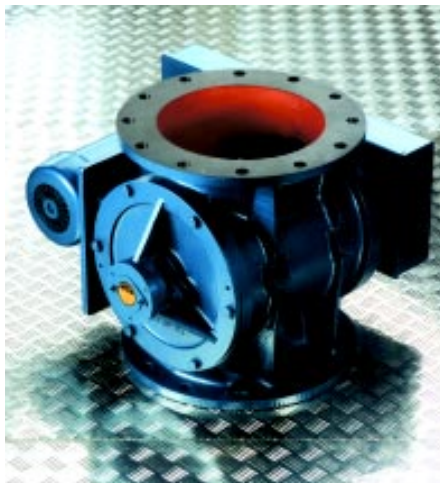
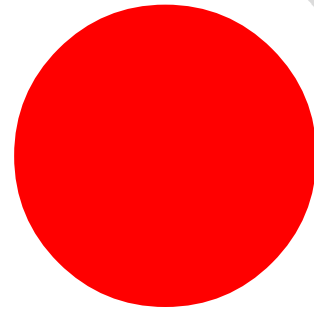

Round Rotary Valve

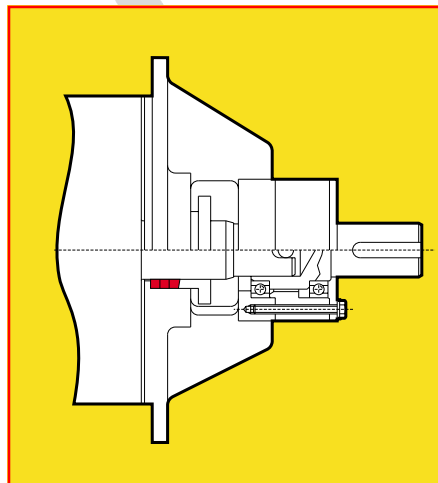

Quick Release Rotor Detail

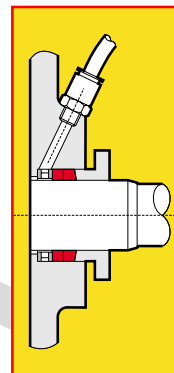

Air Purge Gland

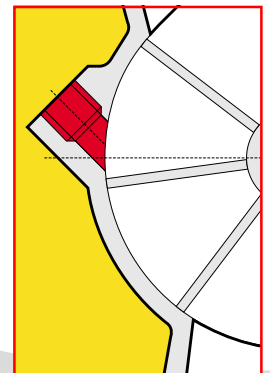

Body Vent

• ROTARY VALVES & AIRLOCKS •

SQUARE INLET

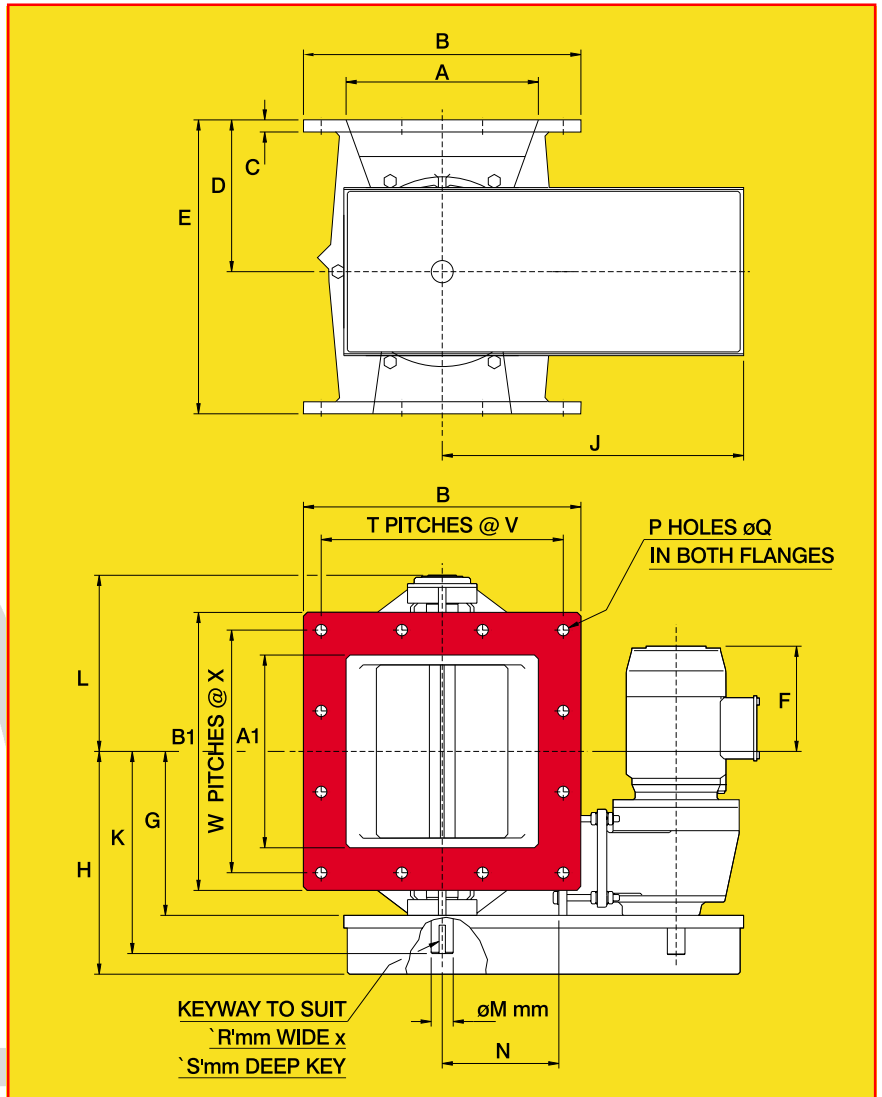

PLANNING-IN DETAIL
FOR GENERAL GUIDANCE ONLY

(TO COVER SAFETY ASPECTS
ASK FOR OUR SAFETY LEAFLETS)

Drillings are Rotolok standards. Variations can be made.

SQUARE ROTARY VALVES

	SIZE	A	A1	B	B1	C	D	E	F	G	H	J	K	L	M	N	P	Q	R	S	T	V	W	X	H.P.
VALVE SIZE	125	127	127	225	225	12	98.5	197	195	159	232	406	220	195	28	143	8	14	8	7	ON APPLICATION				½
	150	152	152	250	250	12	140	280	180	174	247	406	234	195	28	143	12	12	8	7	3	70	3	70	½
	200	203	203	300	300	15	165	330	155	199	272	406	259	219	28	143	12	12	8	7	3	90	3	90	250
	250	254	254	370	370	15	203	388	200	229	322	478	290	249	35	155	12	18	10	8	3	108	3	108	1
	300	305	305	440	440	19	240	465	170	260	353	478	320	279	35	195	12	18	10	8	3	128	3	128	1
	350	356	356	470	470	19	257	514	160	270	363	512	329	289	35	220	12	12	10	8	3	140	3	140	1
	400	406	406	550	550	20	300	580	115	332	425	626	403	352	50	235	12	18	14	9	3	165	3	165	1½
	450	457	457	610	610	20	322	630	85	357	450	626	428	377	50	285	12	18	14	9	3	187	3	187	2
	500	508	508	650	650	20	340	670	120	382	475	700	453	402	50	289	16	18	14	9	4	148	4	148	2
	600	610	610	750	750	20	380	750	115	432	525	700	503	452	50	335	16	18	14	9	4	173	4	173	3
750	750	750	1000	1000	25	500	1000	60	503	643	910	605	522	70	450	24	18	20	12	6	149	6	149	3	
915	915	915	1165	1165	25	600	1200	-25	605	748	1000	707	625	70	540	24	22	20	12	6	175	6	175	5	

All dimensions in mm.

• ROTARY VALVES & AIRLOCKS •

CIRCULAR INLET

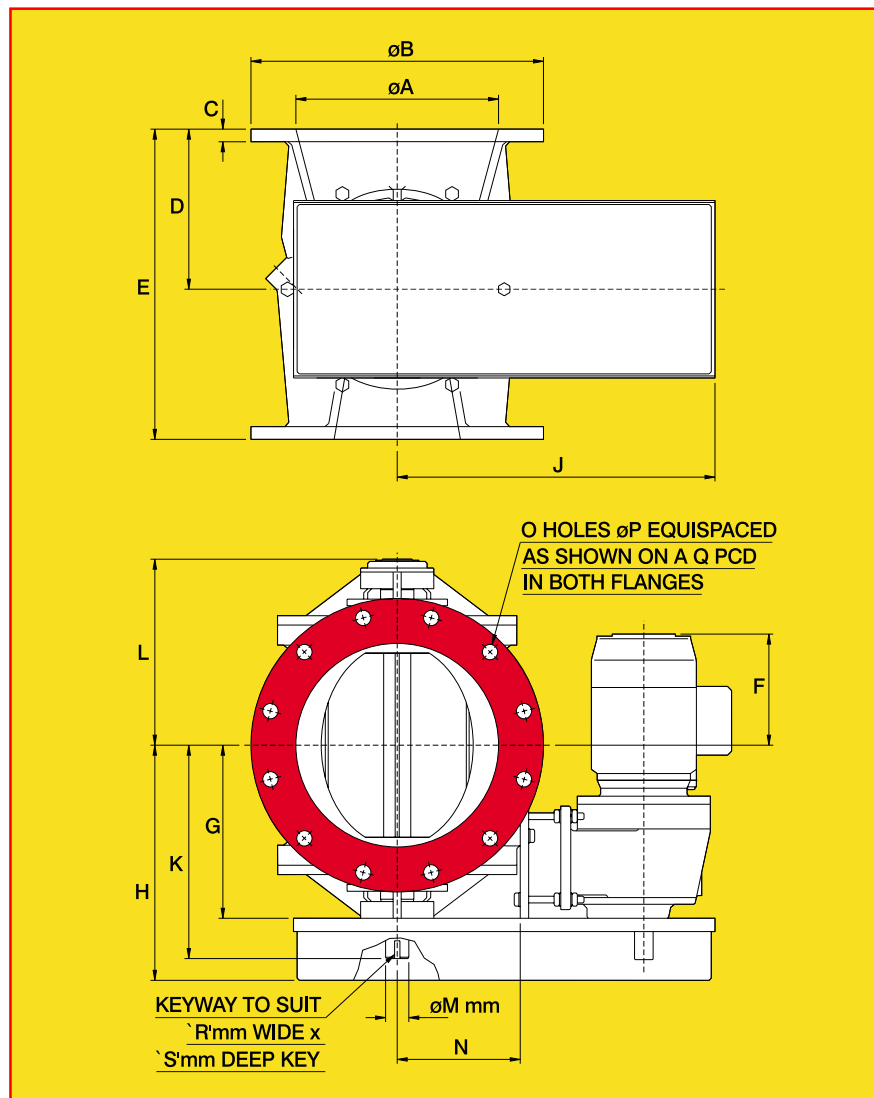
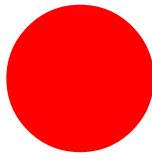

PLANNING-IN DETAIL
FOR GENERAL GUIDANCE ONLY

(TO COVER SAFETY ASPECTS
ASK FOR OUR SAFETY LEAFLETS)

Drillings are Rotolok standards. Variations can be made.

ROUND ROTARY VALVES

	SIZE	A	B	C	D	E	F	G	H	J	K	L	M	N	O	P	Q	R	S	H.P.
VALVE SIZE	50	51	152	10	60	120	*	74	← *DETAILS ON APPLICATION * →											
	85	85	190	10	80	160	*	117	← *DETAILS ON APPLICATION * →											
	125	127	240	12	108	214	200	159	232	406	219	178	28	143	8	18	200	8	7	½
	150	154	285	12	140	270	180	174	247	406	234	194	28	143	8	22	241	8	7	½
	200	203	320	13	160	310	155	199	272	406	259	219	28	143	8	18	280	8	7	½
	250	254	370	15	200	380	200	229	322	478	289	248	35	155	8	18	320	10	8	1
	300	305	440	19	240	465	170	260	353	478	320	279	35	195	12	22	395	10	8	1
	350	356	533	19	270	520	160	270	363	512	332	289	35	220	12	22	445	10	8	1
	400	406	540	20	300	580	110	332	425	626	403	352	50	235	12	22	495	14	9	1½
	450	457	635	20	320	625	80	357	450	626	419	377	50	285	16	32	578	14	9	2
500	508	700	20	340	670	115	382	475	700	453	402	50	289	20	32	635	14	9	2	
600	610	813	20	385	760	115	432	525	700	503	452	50	335	20	35	749	14	9	3	
750	762	984	25	500	1000	45	503	646	910	605	522	70	450	28	35	914	20	12	3	

All dimensions in mm

Rotolok manufactures and casts other valve sizes with rectangular & other non-standard inlets. If you are looking for something considered special it may be in our library of valves.

• ROTARY VALVES & AIRLOCKS •

STANDARD ROTORS

Rotolok basically manufactures four types of rotor as outlined, but to give the plant engineer flexibility many variations can be accommodated, e.g. closed/tipped, reduced volume, staggered blades etc. We will make a rotor to suit your application - not our production.

VALVE SELECTION

The chart below gives theoretical and estimated throughputs on the basis of rotor speed.

The theoretical figure is determined by the swept volume of the valve and is calculated on a pocket fillage of 100%.

In practice this is seldom achieved as density, product characteristics, pressure differential, feeding methods, all affect the valve throughput efficiency.

On these considerations the estimated figures are assessed and are more acceptable for selecting the correct valve. e.g. Select a valve to handle 7 tons/hour of flour at 35 lb/cu. ft. Volume required = $7.0 \times 2000 \div 35 = 400$ cu. ft/hr.

From the chart, two valves economically cover this:

1. 250 Valve at 26 rpm.
2. 300 Valve at 12 rpm.

With flour being sluggish and the 250 unit on its uppermost speed, the selection is limited to the 300 unit.

Factors other than throughput can sometimes determine valve selection. This is particularly true on cyclone and filter applications where the valve inlet size to prevent bridging can become the governing factor, always with the proviso that the potential valve discharge rate exceeds the collecting rate.

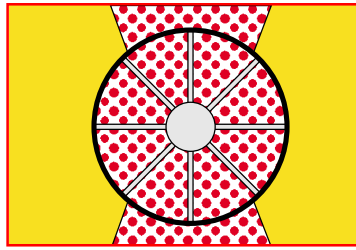

Closed rotor

Suitable for general use on filters, cyclones, silos, screw conveyors and on low pressure conveying systems. Sealing by means of packing gland.

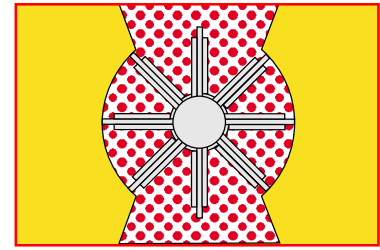

Open adjustable bladed rotor

Suitable for most products and pressure differentials to 20 psi. Blades are adjustable, reversible and replaceable and can be supplied in mild steel, PVC rigid, PTFE, stainless steel etc. to suit particular product. Can be adapted to suit highly abrasive materials.

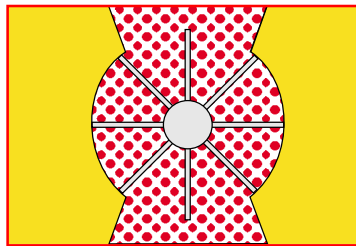

Open fixed bladed rotor

Suitable for general range of products and particularly suitable on conveying systems to pressure of 15 psi. Sealing is by packing gland type with standard packing being fluon or equal.

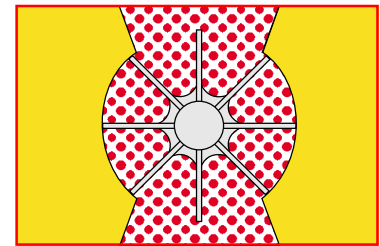

Scalloped rotor

Particularly suitable for "sticky" materials and discharge can be further aided by the application of PTFE coating, generally used in food processes where no product build-up can be tolerated. Pressures to 15 psi are applicable.

Capacity Chart in Cubic Feet/Hr													
	1158	5792	9266	11583	13900	16216	18533	20849	23166	25483	27799	30116	100%
915	1158	5792	8803	10425	12232	13946	15568	16888	18069	18857	19737	20479	Practical
	681	3405	5448	6809	8171	9533	10895	12257	13619	14981	16343	17704	100%
750	681	3405	5176	6128	7190	8198	9152	9928	10623	11086	11604	12039	Practical
	356	1780	2848	3560	4272	4984	5696	6408	7120	7832	8544	9255	100%
600	356	1780	2706	3204	3759	4286	4785	5190	5554	5796	6066	6293	Practical
	205	1024	1639	2048	2458	2868	3277	3687	4097	4506	4916	5326	100%
500	205	1024	1557	1843	2163	2466	2753	2986	3196	3334	3490	3622	Practical
	149	743	1189	1487	1784	2082	2379	2676	2974	3271	3568	3866	100%
450	149	743	1130	1338	1570	1791	1998	2168	2320	2421	2533	2629	Practical
	104	519	830	1037	1245	1452	1660	1867	2075	2282	2490	2697	Practical
400	104	519	789	933	1096	1249	1394	1512	1618	1689	1768	1834	Practical
	65.2	326	521	652	782	912	1043	1173	1303	1434	1564	1694	100%
350	65.2	326	495	587	688	784	876	950	1016	1061	1110	1152	Practical
	45.4	227	363	454	545	636	727	818	908	999	1090	1181	100%
300	45.4	227	354	409	480	547	611	663	708	739	774	803	Practical
	25.6	128	205	256	307	359	410	461	512	564	615	666	100%
250	25.6	128	195	230	270	309	344	373	399	417	437	453	Practical
	12.7	63	101	127	152	177	203	228	253	279	304	329	100%
200	12.7	63	96	114	134	152	171	185	197	206	216	224	Practical
	5.0	25	40	50	60	71	81	91	101	111	121	131	100%
150	5.0	25	38	45	53	61	68	74	79	82	86	89	Practical
	2.8	14	23	28	34	39	45	51	56	62	68	73	100%
125	2.8	14	22	25	30	34	38	41	44	46	48	50	Practical
	.96	4.8	7.7	9.6	11.5	13.4	15.4	17.3	19.2	21.1	23	25	100%
85	.96	4.8	7.3	8.6	10.1	11.5	12.9	14	15	15.6	16.3	17	Practical
	.228	1.1	1.8	2.3	2.7	3.2	3.6	4.1	4.6	5.0	5.5	5.9	100%
50	.228	1.1	1.7	2.1	2.4	2.7	3	3.3	3.6	3.7	3.9	4	Practical
		1	5	8	10	12	14	16	18	20	22	24	26

Rotor Speed RPM

NOTES

Throughput

Certain products when fluidised can greatly exceed the conservative rating and on application, e.g. cement, 100% pocket fillage has been known to occur - similarly light products up to 15lb/cu. ft. the opposite effect can happen.

Temperature

Note: On any application above ambient (21°C) it is important to specify operating temperatures so rotor compensation for expansion can be adjusted as necessary.

Conversions

Divide cubic metres/hr by 0.0283 to obtain cubic feet/hr.

Theoretical capacity 100% pocket fillage efficiency.

Conservative estimated throughput.

• OFFSET ROTARY VALVES •

INTRODUCTION

The main function of a Rotary Valve is to regulate the flow of material from one chamber to another while maintaining a good airlock condition. The material or product being handled is usually dry free flowing powder, dust or granules.

The granule type of product, especially if it is a plastic type, polyethelene or nylon etc., does not shear easily and consequently, without considerable care the standard drop-through type of valve leads to valve seizure and also considerable shock loadings.

To minimize these problems the Offset Rotary Valve ensures lower pocket fillage as its design means that the rotor is still being filled in the upward cycle with the pellets falling away at the shear point. Similarly, the pelican beak distributes the product across the full width of the rotor.

SPECIFICATION

Bodies

Cast Iron, Stainless Steel or Aluminium precision bored.

End Covers

Cast Iron, Stainless Steel or Aluminium spigot located in body for concentricity.

Rotor

Fabricated Mild or Stainless Steel.

Bearings

Generally sealed-for-life-ball type rigged outboard or high temperature type above 250° C.

Shaft Seal

Gland type with PTFE packing.

Drive

TEFC geared motor unit side wall mounted to valve body and complete with taper lock sprockets chain drive all in an enclosed guard.

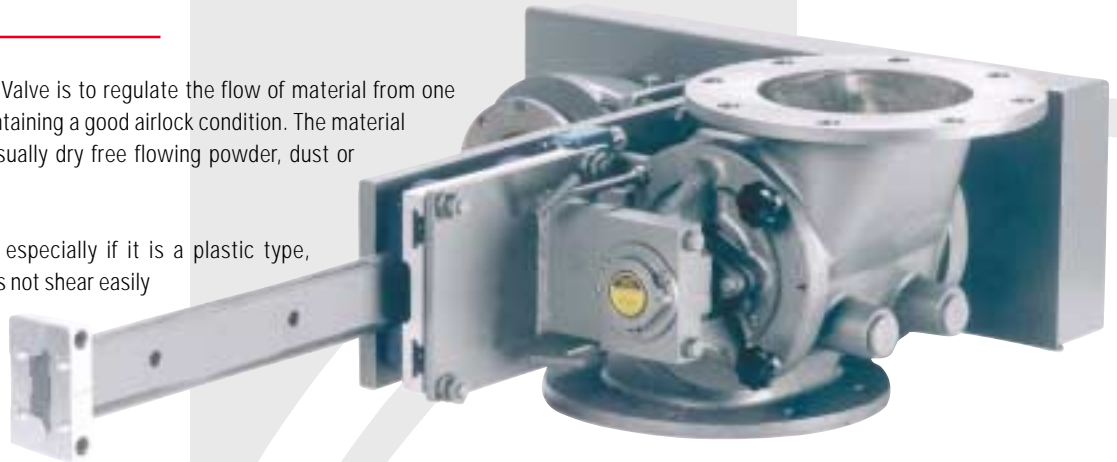

IMPORTANT FEATURES

- Maximum number of blades in contact with body at one time without affecting throughput.
- Good throat opening at valve entry allowing high pocket filling efficiency.
- Robust body adequately stiffened to prevent distortion.
- Heavy shaft diameters minimising deflection.
- Outboard bearings for non-contamination.
- Packing gland type seals.
- Maximising valve speed to 25 rpm - prolonging life, ensuring good throughput.
- Precision machining of components.

All add up to Rotolok standards.



• OFFSET ROTARY VALVES •

RECTANGULAR OFFSET ROTARY VALVES



PLANNING-IN DETAIL FOR
GENERAL GUIDANCE ONLY

(TO COVER SAFETY
ASPECTS ASK FOR
OUR SAFETY LEAFLETS)

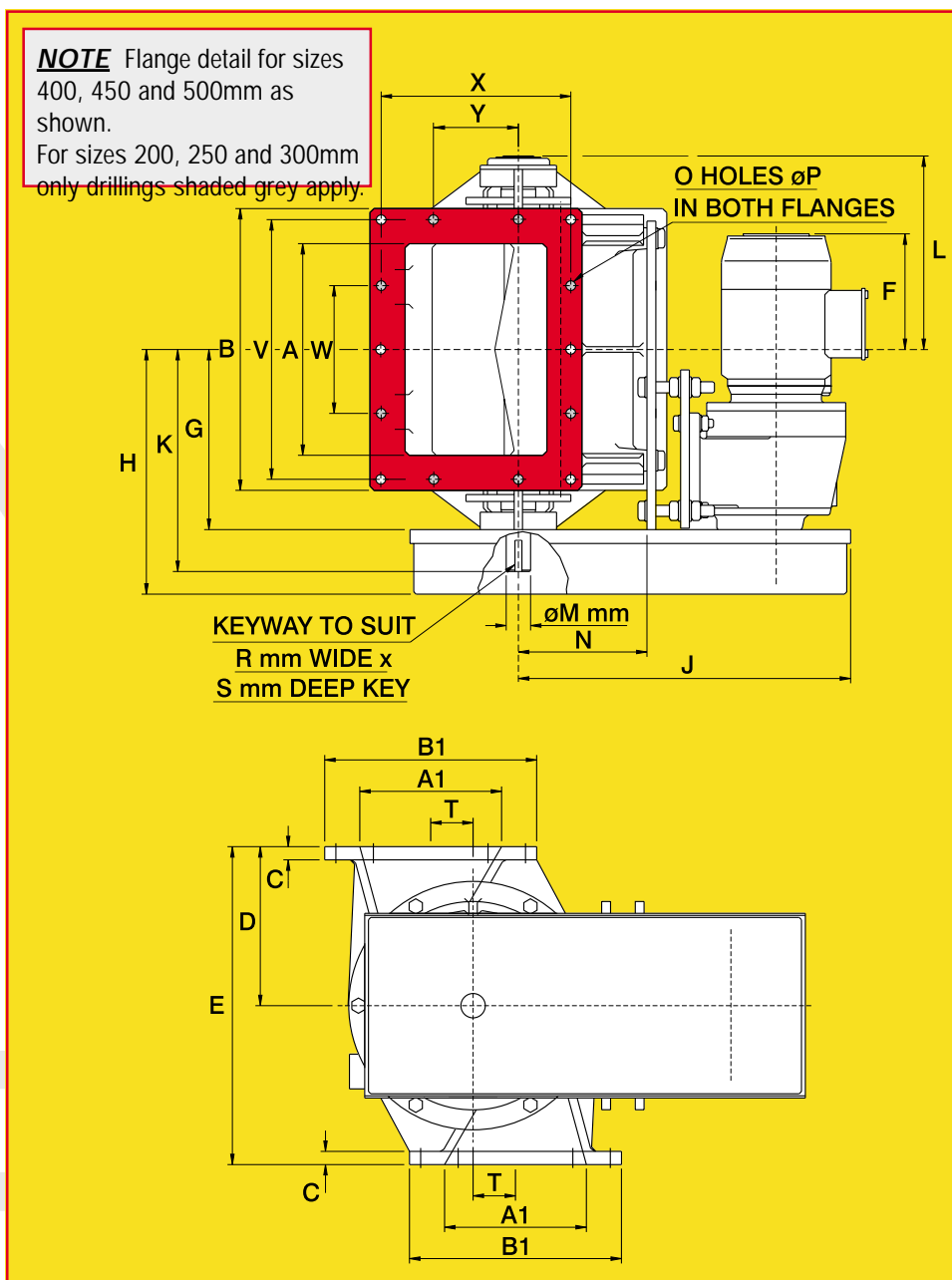

Drillings are Rotolok standards. Variations can be made.

RECTANGULAR OFFSET ROTARY VALVES

SIZE	A	A1	B	B1	C	D	E	F	G	H	J	K	L	M	N	O	P	R	S	T	V	W	X	Y	H.P.	
VALVE SIZE	200	200	152	305	254	12	165	330	240	199	272	450	260	218	28	133	8	14	8	7	41	273	178	222	127	1
	250	254	178	356	280	15	204	408	215	229	322	478	290	248	35	155	8	14	10	8	48	324	152	248	152	1
	300	305	204	406	305	19	229	458	180	260	353	528	320	279	35	185	8	14	10	8	61	374	184	273	165	1 1/2
	400	406	254	558	406	22	279	558	125	332	425	626	403	351	50	235	14	19	14	9	86	514	266	362	152	1 1/2
	450	458	280	610	432	22	327	654	155	357	450	666	419	376	50	260	14	19	14	9	86	565	280	387	152	2
	500	508	305	660	457	25	356	712	130	382	475	666	453	401	50	285	14	19	14	9	99	616	304	413	152	3

All dimensions in mm.
Dimensions subject to change without notice

• OFFSET ROTARY VALVES •

ROUND OFFSET ROTARY VALVES



PLANNING-IN DETAIL
FOR GENERAL
GUIDANCE ONLY

(TO COVER SAFETY
ASPECTS ASK FOR OUR
SAFETY LEAFLETS)

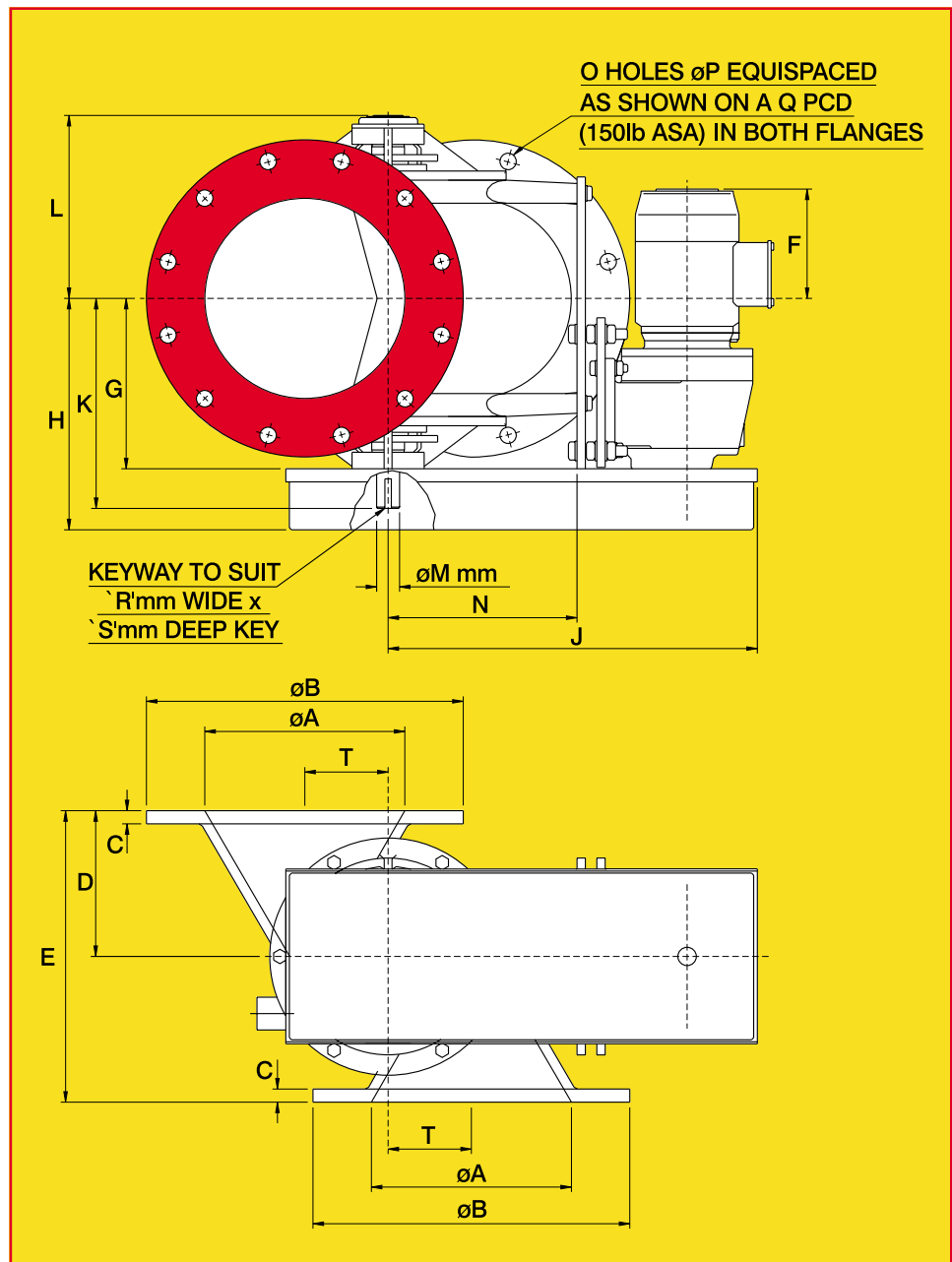

Drillings are Rotolok standards. Variations can be made.

ROUND ROTARY VALVES

	SIZE	ϕA	ϕB	C	D	E	F	G	H	J	K	L	ϕM	N	O	ϕP	ϕQ	R	S	T	H.P.
VALVE SIZE	200	204	343	16	165	330	250	199	272	517	260	218	28	200	8	22	298	8	7	86	1
	250	254	406	19	190	380	220	229	311	564	290	248	35	247	12	25	362	10	8	108	1
	300	305	483	20	222	444	190	260	353	626	320	279	35	288	12	25	432	10	8	127	1 1/2
	350	356	533	22	266.7	533.4	195	270	363	652	329	289	35	330	12	28	476	10	8	140	1 1/2
	500	508	700	25	356	712	114	382	475	722	453	404	50	340	20	32	635	14	9	200	3

All dimensions in mm.
Dimensions subject to change without notice

• OFFSET ROTARY VALVES •

VALVE SELECTION

The chart below gives theoretical and estimated throughputs on the basis of rotor speed.

The theoretical figure is determined by the swept volume of the valve and is calculated on a pocket fillage of 100%.

In practice this is seldom achieved as density, product characteristics, pressure differential, feeding methods, all affect the valve throughput efficiency.

On these considerations the estimated figures are assessed and are more acceptable for selecting the correct valve. e.g. Select a valve to handle 7 tons/hour of flour at 35 lb/cu. ft. Volume required = $7.0 \times 2000 \div 35 = 400$ cu. ft/hr.

From the chart, two valves economically cover this:

1. 250 Valve at 26 rpm.
2. 300 Valve at 12 rpm.

With flour being sluggish and the 250 unit on its uppermost speed, the selection is limited to the 300 unit.

Factors other than throughput can sometimes determine valve selection. This is particularly true on cyclone and filter applications where the valve inlet size to prevent bridging can become the governing factor, always with the proviso that the potential valve discharge rate exceeds the collecting rate.

Capacity Chart in Cubic Feet/Hr													
500	205	1024	1639	2048	2458	2868	3277	3687	4097	4506	4916	5326	100%
	205	1024	1557	1843	2163	2466	2753	2986	3196	3334	3490	3622	Practical
450	149	743	1189	1487	1784	2082	2379	2676	2974	3271	3568	3866	100%
	149	743	1130	1338	1570	1791	1998	2168	2320	2421	2533	2629	Practical
400	104	519	830	1037	1245	1452	1660	1867	2075	2282	2490	2697	Practical
	104	519	789	933	1096	1249	1394	1512	1618	1689	1768	1834	Practical
350	65.2	326	521	652	782	912	1043	1173	1303	1434	1564	1694	100%
	65.2	326	495	587	688	784	876	950	1016	1061	1110	1152	Practical
300	45.4	227	363	454	545	636	727	818	908	999	1090	1181	100%
	45.4	227	354	409	480	547	611	663	708	739	774	803	Practical
250	25.6	128	205	256	307	359	410	461	512	564	615	666	100%
	25.6	128	195	230	270	309	344	373	399	417	437	453	Practical
200	12.7	63	101	127	152	177	203	228	253	279	304	329	100%
	12.7	63	96	114	134	152	171	185	197	206	216	224	Practical
	1	5	8	10	12	14	16	18	20	22	24	26	
Rotor Speed RPM													

NOTES ON VALVE SELECTION

Throughput

Certain products when fluidised can greatly exceed the conservative rating and on application, e.g. cement, 100% pocket fillage has been known to occur - similarly light products up to 15lb/cu. ft. the opposite effect can happen.

Temperature

Note: On any application above ambient (21°C) it is important to specify operating temperatures so rotor compensation for expansion can be adjusted as necessary.

Conversions

Divide cubic metres/hr by 0.0283 to obtain cubic feet/hr.

OPTIONS

- Body Vents
- Air Purge Glands
- Quick Release Rotors
- Direct Coupled Drives
- Hard Chrome Internals
- Electroless Nickel Plating
- Shear Plate Deflectors
- Speed Switches
- Dropout Boxes
- V.S. Drives
- Flameproof Motors
- Vent Boxes etc.

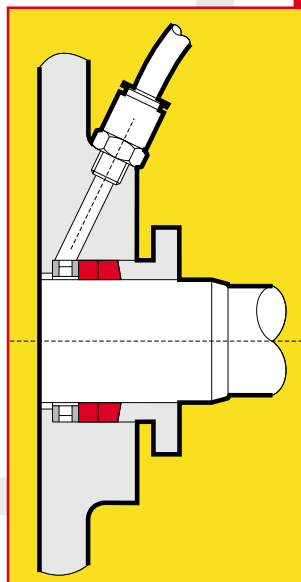

Air Purge Gland

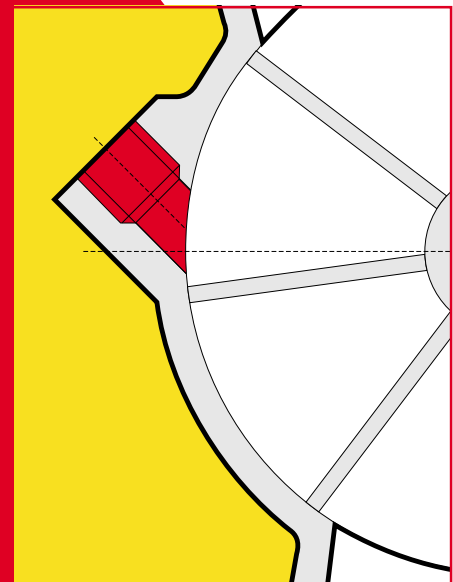

Body Vent

DUST COLLECTOR VALVE

INTRODUCTION

Rotolok has been an extremely competitive manufacturer of Rotary Valves since its formation in 1972.

It has grown considerably over this period world wide.

Having initially introduced a direct coupled Rotary Valve some 20 years ago with limited success, but with the advent of many competitors entering this field it is felt that Rotolok needs to re-focus its attention to the low cost end of the market.

Rotolok as usual will not see its market eroded and this leaflet introduces a Dust Valve significantly cheaper than that of its competitors.

"DCV" SERIES ROTARY VALVE

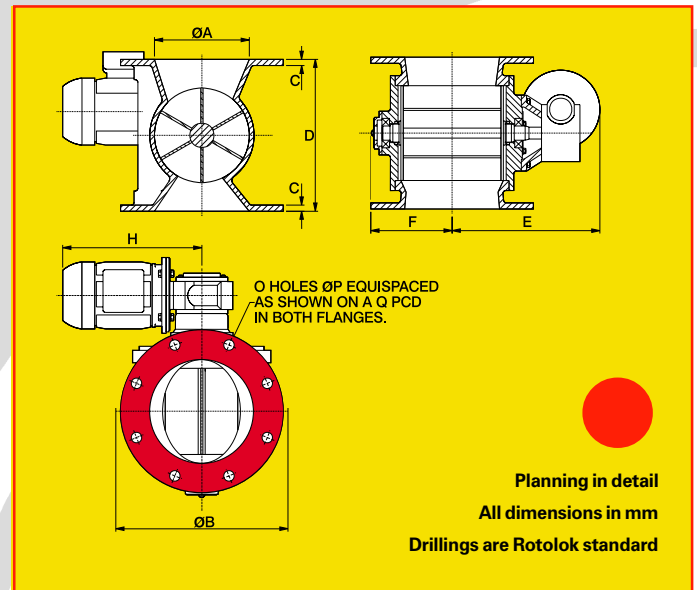

Dimensions are approximate and subject to change without notice.

Model	cu.ft/hr @ 1 rpm	HP	A	B	C	D	E	F	H	O	P	Q	Weight (lbs)
150	5	1/2	154	285	12	270	296	146	356	8	18	241	152
200	12.7	1/2	203	320	12	310	320	172	356	8	18	280	183
250	25.6	3/4	254	368	15	380	350	204	382	8	18	320	256
300	45.4	3/4	305	440	19	465	388	235	382	12	18	395	386

ASK FOR OUR SAFETY LEAFLETS
OR SEE OUR WEBSITE

TRY IT - YOU'LL LIKE IT

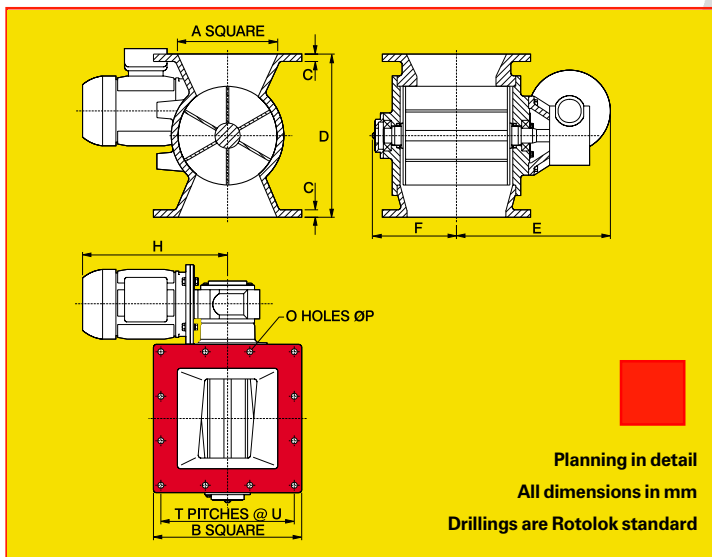

Dimensions are approximate and subject to change without notice.

Model	cu.ft/hr @ 1 rpm	HP	A	B	C	D	E	F	H	O	P	T	U	Weight (lbs)
150	5	1/2	152	250	12	280	296	146	356	12	12	3	70	152
200	12.7	1/2	203	300	12	330	320	172	356	12	12	3	90	183
250	25.6	3/4	254	370	18	390	350	204	382	12	12	3	108	256
300	45.4	3/4	305	440	18	465	388	235	382	12	12	3	128	386

ASK FOR OUR SAFETY LEAFLETS
OR SEE OUR WEBSITE

SPECIFICATION

The general market place cover Cyclones, Bag Houses and Gravity Feed applications with pressures around ± 3 PSI.

Body

Cast Iron Precision Bored

End Covers

Cast Iron Precision Machined and Spigot Located into Valve Body

Rotor

Fabricated Mild Steel Closed (Shrouded) Type Fully Machined

Bearings

Ball Type Rugged Inboard Sealed for Life

Seal

Shaft Seal Rubber Lip Type

Drive

Motorized Worm Box Shaft Mounted on Rotor and Fitted with Standard I.E.C. Motor TEFC 3PH/50HZ Flange Mounted to Worm Box

Valve Speed

Sizes 150 & 200 - 22 RPM

Sizes 250 & 300 - 25 RPM

Rotolok Limited, 1 Millennium Place
Tiverton Business Park
Tiverton, Devon EX16 6SB

Tel: 01884 232232 Fax: 01884 232200

e-mail: sales@rotolok.co.uk website: www.rotolok.co.uk

• ODDBALL ROTARY VALVES •

INTRODUCTION

This brochure simply outlines Rotolok's range of special sized Rotary Airlocks. However, Rotolok manufactures even more than are listed here, including some round inlets to square outlets and the range is continuously being extended.

For full specification, rotor selection and other options please refer to our Rotary Valve & Airlocks brochure.

If you require a special valve that does not appear here please contact our sales office as we may design and manufacture to your requirements.

STANDARD FEATURES

- Maximum number of blades in contact with body at one time without affecting throughput.
- Good throat opening at valve entry allowing high pocket filling efficiency.
- Minimum clearance at rotor tips and sides with body.
- Robust body adequately stiffened to prevent distortion.
- Heavy shaft diameters minimising deflection.
- Outboard bearings for non-contamination.
- Packing gland type seals.
- Maximising valve speed to 25 rpm - prolonging life, ensuring good throughput.
- Precision machining of components.



All add up to Rotolok standards.

SPECIFICATION

Bodies

Cast Iron, Stainless Steel or Aluminium precision bored.

End Covers

Cast Iron, Stainless Steel or Aluminium spigot located in body for concentricity.

Rotor

Fabricated Mild or Stainless Steel.

Bearings

Generally sealed-for-life-ball type rigged outboard or high temperature type above 250° C.

Shaft Seal

Gland type with PTFE packing.

Drive

TEFC geared motor unit side wall mounted to valve body and complete with taper lock sprockets chain drive all in an enclosed guard.

OPTIONS

- Quick Release Rotors
- Direct Coupled Drives
- Air Purge Glands
- Body Vents
- Vent Boxes
- Dropout Boxes
- V.S. Drives
- Speed Switches
- Flameproof Motors
- Shear Plate Deflectors
- Electroless Nickel Plating
- Hard Chrome Internals etc.

Drillings are Rotolok standards. Variations can be made.
SPECIAL ROUND INLET BARESHAFT ROTARY VALVES

NOMINAL INLETØ x BORE	ØA	ØB	C	D	E	G	K	L	ØM	N	O	P	Q	R	S	AB	AC	AD	AE	AF	ft³/rev
12.5 x 19	12.7	89	7	53	106	44	74	55	9.5	-	4	16	60.5	3	3	-	-	-	-	-	8.7x10 ⁻⁵
150 x 170	150	285	12	130	260	198	250	217	28	110	8	22	240	8	7	125	146	100	M10	18	0.11
150 x 200	152	254	8	124	248	174	235	193	28	127	6	11	222	8	7	94	130	104	M10	20	0.167
175 x 210	175	315	12	160	320	220	270	239	28	130	8	22	270	8	7	125	190	100	M10	18	0.218
200 x 260	200	340	12	185	370	255	315	274	28	160	8	22	295	8	7	138	234	125	M12	18	0.423
200 x 250	203	320	12	156	311	219	280	238	28	175	8	10	280	8	7	94	250	104	M10	20	0.394
200 x 300	205	343	19	220	465	260	320	279	35	185	8	22	298	10	8	100	320	140	M16	30	0.75
250 x 310	250	395	15	215	430	280	340	299	35	190	12	22	350	10	8	138	284	125	M12	18	0.705
250 x 310	250	406	15	215	430	280	340	299	35	190	12	25	362	10	8	138	284	125	M12	18	0.705
300 x 380	300	445	16	260	520	330	390	349	35	225	12	22	400	10	8	150	360	125	M12	22	1.33
350 x 450	350	505	21	305	610	365	425	384	50	270	16	22	460	14	9	155	420	125	M12	22	2.216

Dimensions in millimetres unless stated
 DIMENSIONS SUBJECT TO CHANGE WITHOUT NOTICE

• ODDBALL ROTARY VALVES •

ROUND SPECIAL ROTARY VALVES

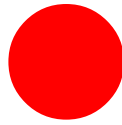

RECTANGULAR & SQUARE SPECIAL ROTARY VALVES

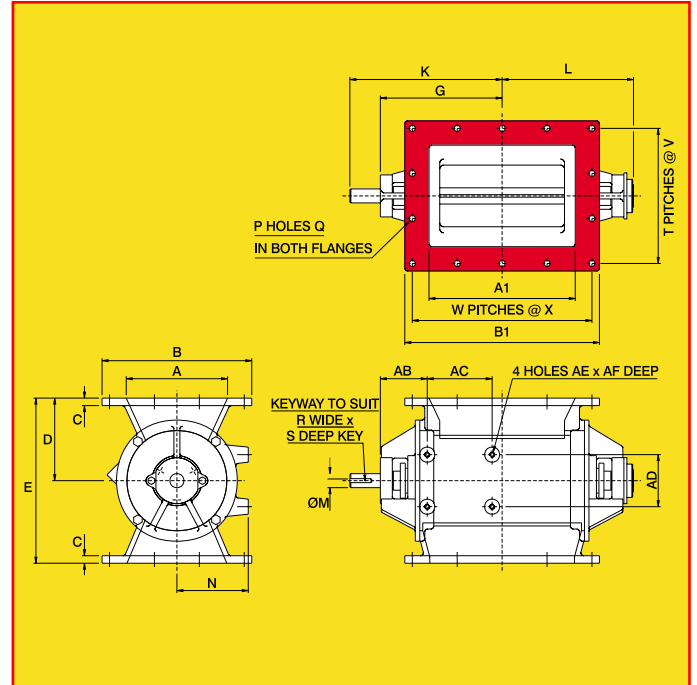
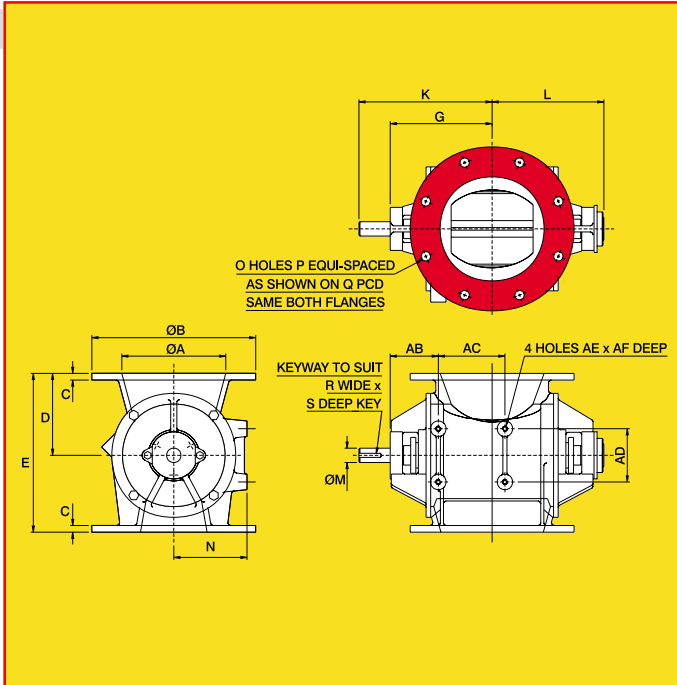

PLANNING-IN DETAIL FOR GENERAL GUIDANCE ONLY

(TO COVER SAFETY ASPECTS ASK FOR OUR SAFETY LEAFLETS)

Drillings are Rotolok standards. Variations can be made.

RECTANGULAR & SQUARE SPECIAL ROTARY VALVES

NOMINAL INLET SIZE	A	A1	B	B1	C	D	E	G	K	L	M	N	P	Q	R	S	T	V	W	X	AB	AC	AD	AE	AF	ft ³ /rev
80 x 300	80	300	150	330	10	85	170	249	310	268	28	-	6	11	8	7	1	114	2	127	-	-	-	-	-	0.109
100 x 100	102	102	171	171	10	95	190.5	146	196	165	25	87	4	12	8	7	1	146	1	146	101	90	152	M10	20	0.056
100 x 150	102	152	164	212	10	121	241	185	246	204	28	126	8	10	8	7	0/A	0/A	0/A	0/A	103	127	102	M10	20	0.189
230 x 230	229	229	305	305	10	132	264	219	280	238	28	133	12	12	8	7	0/A	0/A	0/A	0/A	98	127	102	M10	20	0.223
125 x 250	127	254	203	312	12	134	267	227	288	246	28	126	12	M8	8	7	0/A	0/A	0/A	0/A	94	110	104	M10	20	0.265
125 x 300	127	305	203	363	12	134	267	253	314	272	28	126	12	M8	8	7	0/A	0/A	0/A	0/A	94	110	104	M10	20	0.316
200 x 460	200	460	300	560	15	165	330	329	427	348	35	133	16	14	10	8	0/A	0/A	4	130	124	152	178	M10	20	0.411
200 x 600	200	600	300	700	15	165	330	399	460	418	28	150	16	14	8	7	0/A	0/A	4	165	94	130	104	M10	20	0.554
230 x 270	233	270	330	370	16	205	410	247	321	266	40	185	12	12	12	8	3	93	3	107	122	250	300	M12	20	0.534
350 x 390	356	387	470	502	16	225.5	451	305	365	323	35	194	12	14	10	8	0/A	0/A	0/A	0/A	110	152	178	M10	20	0.956
300 x 1220	305	1219	419	1,372	15	229	457	719	780	738	35	185	28	11	10	8	3	127	0/A	0/A	100	152	178	M10	20	2.198
250 x 250	250	250	365	365	14	250	500	263	326	282	40	207	12	14	12	8	3	110	3	110	143	240	290	M16	30	0.731
250 x 250	254	254	330	330	13	203	406	267	338	287	50	206	8	11	14	9	2	152	2	152	143	248	203	M10	25	0.959
250 x 350	250	350	350	450	12	240	480	270	329	289	35	220	12	13	10	8	3	104	3	140	97	345	145	M12	20	1.089
300 x 580	305	578	464	778	25	305	610	429	489	449	50	286	18	18	14	9	3	133	5	143	156	546	330	M16	40	3.189
460 x 815	460	815	610	965	18	305	610	526	607	545	50	290	18	18	14	9	3	178	6	152.4	125	415	140	M16	30	5.469

Dimensions in millimetres unless stated
DIMENSIONS SUBJECT TO CHANGE WITHOUT NOTICE

• BLOWING SEALS •

INTRODUCTION

Blowing Seals have been introduced to meet the specific needs of the pneumatic conveying industry and are a natural extension to the Rotary Airlock, both being used to regulate the flow of dry powder, dust or granular product while maintaining an airlock.

However, the Blowing Seal has several advantages for the specialist as it introduces high pressure conveying air through the valve body and rotor pocket ensuring - **HIGH EFFICIENCY THROUGHPUT WITH EFFECTIVE PRESSURE DROP.**

This is achieved by the fact that more blades are in contact for longer periods with the valve body, resulting in less air leakage - and blowing through the rotor each rotor pocket is efficiently emptied.

The Rotolok range of seals are robustly constructed with an emphasis on close tolerances and minimal eccentricities, making the units suitable for the majority of pneumatic conveying applications.

STANDARD FEATURES

- Maximum number of blades in contact with valve body at one time without affecting throughput.
- Streamlined entry and discharge of conveying air through valve.
- Good throat opening at valve entry allowing high pocket filling efficiency.
- Compact design minimizing headroom.
- Minimum clearance at rotor tips and sides with body.
- Robust body adequately stiffened to prevent distortion.
- Heavy shaft diameters minimizing deflection.
- Outboard bearings for non-contamination - option for high temperature.
- Packing gland type seals with air purging option.
- Precision machining of components.
- Abrasive duty types.
All add up to Rotolok standards.



Round Blowing Seal

SPECIFICATION

Bodies

Cast Iron or Stainless Steel
precision machined.

End Covers

Cast Iron or Stainless Steel
spigot located in body.

Rotor

Fabricated Mild or Stainless Steel
fixed bladed open type.

Bearings

Ball type sealed-for-life - alternative
high temperature to 400° C.

Shaft Seal

PTFE packing gland.

Drive

TEFC geared motor unit side wall mounted
to valve body and complete with taper lock
chain drive in an enclosed guard.
Option: flameproof, variable speed etc.

OPTIONS

- Hard Chrome Internals etc.
- Electroless Nickel Plating
- Shear Plates Deflectors
- Direct Coupled Drives
- Flameproof Motors
- Air Purge Glands
- Speed Switches
- Body Vents
- Vent Boxes
- V.S.Drives

• BLOWING SEALS •

RETANGULAR BLOWING SEAL



PLANNING-IN DETAIL
FOR GENERAL GUIDANCE ONLY
All dimensions in mm.

(TO COVER SAFETY ASPECTS
ASK FOR OUR SAFETY LEAFLETS)

Drillings are Rotolok standards.
Variations can be made.

All dimensions in millimetres

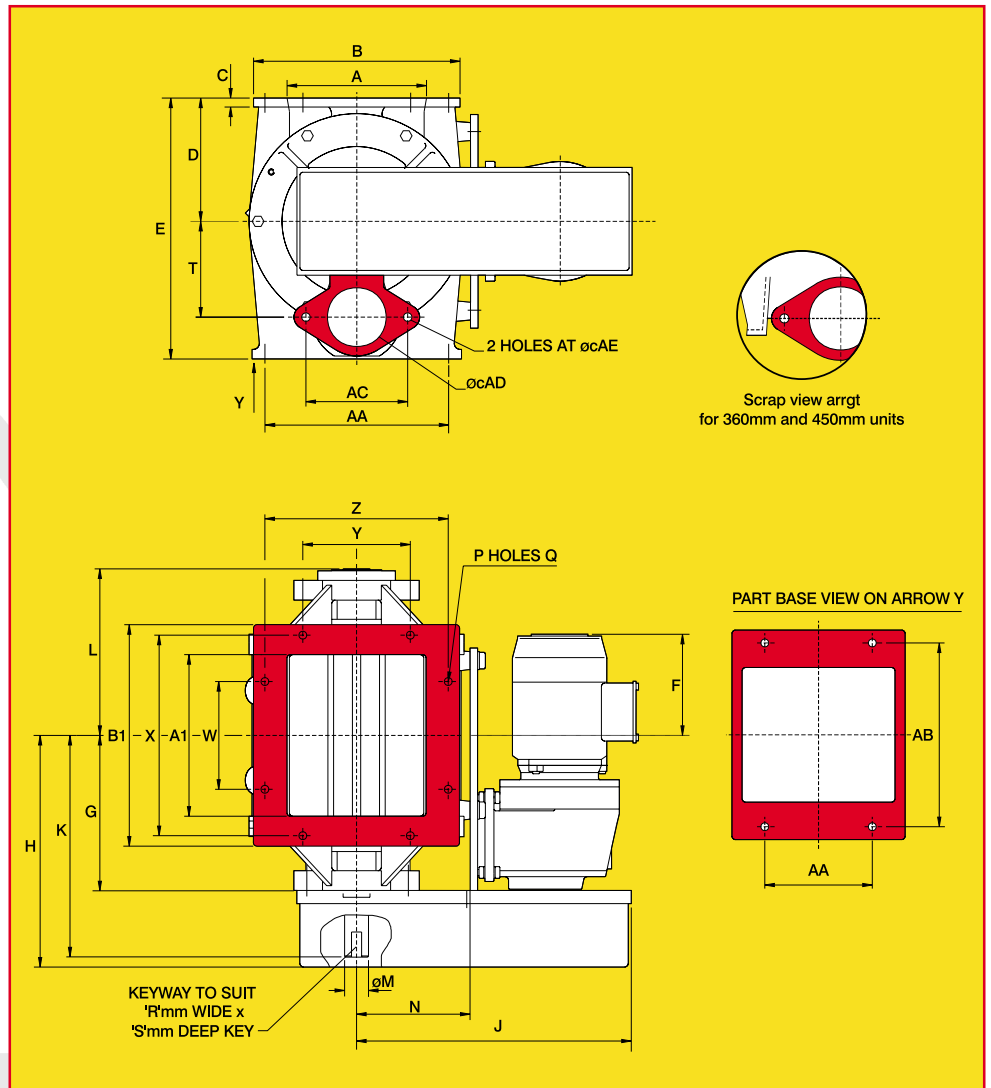

SIZE	A	A1	B	B1	C	D	E	F	G	H	J	K	L	M	N
125	125	125	205	205	12	110	240	225	159	252	405	219	180	28	95
200	200	200	300	300	12	160	340	185	199	290	405	258	218	28	125
240	180	200	280	280	15	180	340	233	225	318	435	286	244	40	165
280	225	270	345	370	15	206	436	200	259	352	460	320	278	40	190
360	255	350	350	450	15	240	466	143	315	443	595	386	333	50	227
450	310	400	410	510	15	290	500	108	350	478	625	421	370	50	270

SIZE	P	Q	R	S	T	W	X	Y	Z	AA	AB	AC	AD	AE	H.P.
125	8	10	8	7	80	90	170	90	170	90	125	95	50	11.5	1/2
200	8	13	8	7	100	130	270	130	270	130	190	130	75	11.5	1/2
240	8	*	12	8	110	130	250	100	250	130	225	110	65	14	1
280	8	13	12	8	160	180	335	180	307	180	307	170	98	14	1
360	10	14	14	9	200	300	420	180	320	300	320	180	110	14	1 1/2
450	10	14	14	9	230	320	480	220	380	320	380	200	125	14	1 1/2

• BLOWING SEALS •

ROUND BLOWING SEAL



PLANNING-IN DETAIL
FOR GENERAL GUIDANCE ONLY
All dimensions in mm.

(TO COVER SAFETY ASPECTS
ASK FOR OUR SAFETY LEAFLETS)

Drillings are Rotolok standards.
Variations can be made.

All dimensions in millimetres

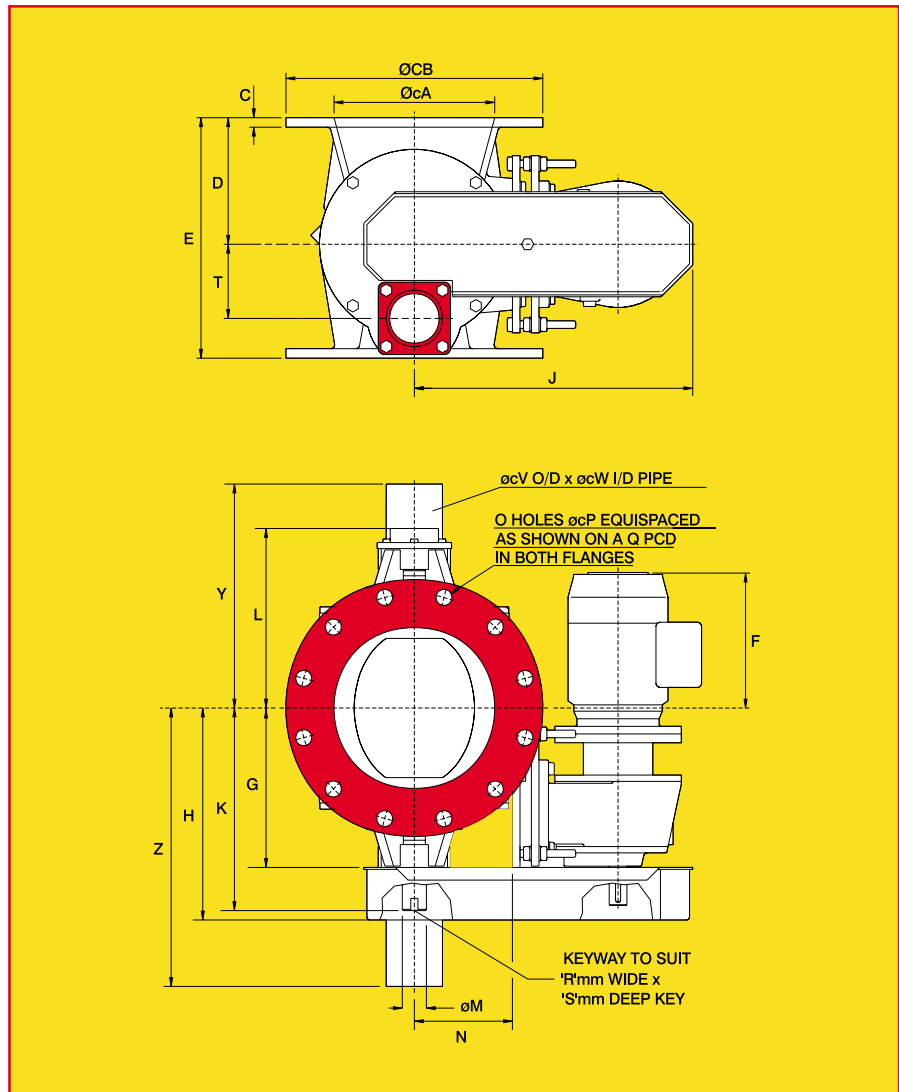

	SIZE	A	B	C	D	E	F	G	H	J	K	L	M
VALVE SIZE	150	154	285	13	140	270	225	192	266	400	260	218	30
	200	203	343	13	160	310	200	218	291	400	285	243	30
	250	254	406	15	200	380	230	251	335	479	320	262	35
	300	305	483	19	240	465	200	281	365	520	350	292	35
	400	406	597	19	300	580	110	347	475	565	456	354	60

	SIZE	N	O	P	Q	R	S	T	V	W	Y	Z	H.P.
VALVE SIZE	150	143	8	22	241	8	7	85	60	52	295	368	1/2
	200	143	8	23	298	8	7	93	73	63	320	393	1/2
	250	155	12	25	362	10	8	117	89	78	354	440	1
	300	195	12	25	432	10	8	142	102	90	384	467	1
	400	235	16	29	540	18	11	178	141	128	450	568	1/2

• BLOWING SEALS •

VALVE SELECTION

The chart below gives theoretical and practical throughputs on the basis of rotor speed.

The theoretical efficiency is seldom achieved in practise as density, product characteristics, pressure differential, feeding methods etc. all affect valve throughput.

On these considerations the practical figures are assessed and are more acceptable for correct valve selection.

e.g. Select a valve to handle 7½ tonnes/hour of flour at 34lb/cu. ft.
 Volume required = $7.5 \times 2200/34 = 485$ cu. ft/hr.

From the chart the 280 unit running at 18 rpm covers this requirement.

Certain products when fluidised can exceed the conservative ratings. Similarly, light products - 10lb/cu.ft. the opposite effect can occur.

IF IN DOUBT CONSULT OUR TECHNICAL DEPARTMENT.

		Capacity Chart in Cubic Feet/Hr												
Valve Size		Rotor Speed RPM												
		1	5	8	10	12	14	16	18	20	22	24	26	
450		120	600	960	1200	1440	1680	1920	2160	2400	2640	2880	3120	100%
	Practical	120	600	920	1128	1320	1510	1670	1790	1944	2085	2216	2340	
400		104	519	830	1037	1245	1452	1660	1867	2075	2282	2490	2697	100%
	Practical	104	519	789	933	1096	1249	1394	1512	1618	1689	1768	1834	
360		66	330	528	660	792	924	1056	1188	1320	1452	1584	1716	100%
	Practical	66	330	507	620	725	830	915	986	1068	1147	1218	1287	
300		45.4	227	363	454	545	636	727	818	908	999	1090	1181	100%
	Practical	45.4	227	354	409	480	547	611	663	708	739	774	803	
280		32.5	162	260	325	390	455	520	585	650	715	780	845	100%
	Practical	32.5	162	249	305	355	405	450	485	526	564	600	634	
250		25.6	128	205	256	307	359	410	461	512	564	615	666	100%
	Practical	25.6	128	195	230	270	309	344	373	399	417	437	453	
240		17	85	136	170	204	238	272	306	340	374	408	442	100%
	Practical	17	85	130	160	184	212	235	254	275	296	314	331	
200		12.3	62	98	123	148	172	197	221	246	271	295	320	100%
	Practical	12.3	62	94	116	135	150	171	183	199	214	227	240	
150		5.0	25	40	50	60	71	81	91	101	111	121	131	100%
	Practical	5.0	25	38	45	53	61	68	74	79	82	86	89	
125		2.7	13.5	25.5	27	32.5	38	43	49	54	59	65	70	100%
	Practical	2.7	13.5	20.5	24	29	32.5	37	40	42	44	46	48	

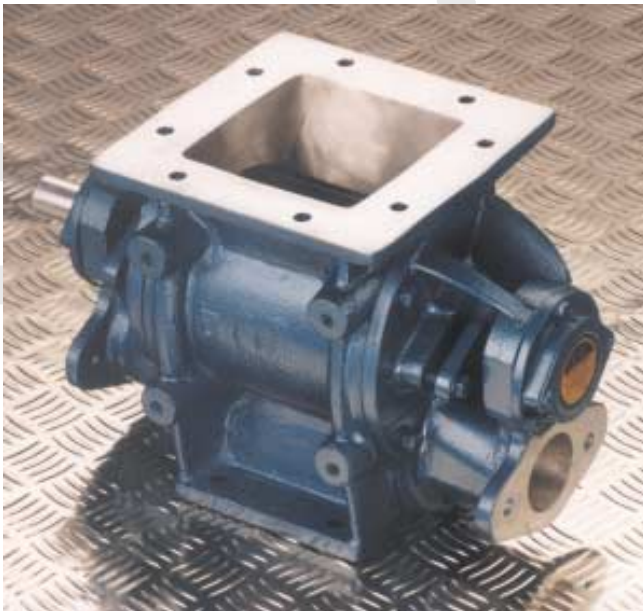

Retangular Blowing Seal

NOTES

Throughput

Certain products when fluidised can greatly exceed the conservative rating and on application, e.g. cement, 100% pocket fillage has been known to occur - similarly light products up to 15lb/cu. ft. the opposite effect can happen.

Temperature

Note: On any application above ambient (21°C) it is important to specify operating temperatures so rotor compensation for expansion can be adjusted as necessary.

Conversions

Divide cubic metres/hr by 0.0283 to obtain cubic feet/hr.

Theoretical capacity 100% pocket fillage efficiency.

Conservative estimated throughput.

• ROTOSPEED SWITCH •

SHAFT ROTATION MONITOR

INTRODUCTION

The Rotospeed Switch was developed initially to economically monitor Rotolok's Rotary Valves around the clock, replacing labour intensive visual supervision.

Other applications (e.g. belt conveyors, elevators and vee drives) however require more sophisticated overspeed and underspeed detection, so the Rotospeed has been upgraded to meet these needs.

OPERATION

The heart of the switch is its sensing head with its built in switching device. The head detects the blades of a rotor mounted on the shaft to be monitored. The sensing head switch is activated when the rotor frequency matches or exceeds the switches setting frequency. The switch will deactivate when the rotor frequency falls below the switches setting frequency.

The switch is suitable for operation over a range of 2.5 to 200 RPM but this range can be extended if details are given on application.

Care must be taken not to overload the switch and these details are as charted. In all cases it is recommended to install prior to the Rotospeed, a 5 A protection fuse.

Different sensing heads can be used for alternative applications, (details given on application).

The shaft being monitored should be tapped 12mm in accordance with the planning in drawing and to overcome the problem of eccentricity or the hole not being coaxial, a locating plate should be fitted to stop rotation of the switch. By locating rather than bolting the Rotospeed firmly to the bracket, bearing overload is prevented.

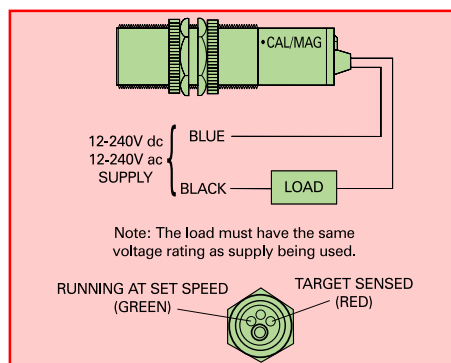

CONSTRUCTION

The total unit is housed in a weatherproof aluminium housing and can be directly coupled to the monitored shaft and is suitable for running in clockwise or anticlockwise direction. Housing can be cast in alternative materials, details on application.

The proximity switch provides an open circuit when de-energised and operates from a 12 - 240V DC or 24 - 240V AC 50/60 HZ supply. Mounting positions can be horizontal, vertical or at any convenient angle.

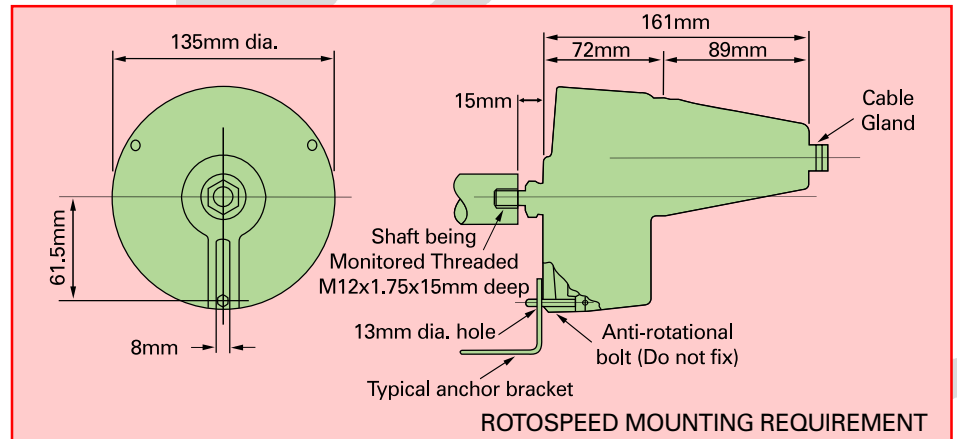

SPEED ADJUSTMENT

If it is necessary to recalibrate the Rotospeed to a new speed or start-up delay, proceed as follows:-

- Switch off the supply to the machinery and Rotospeed.
- Undo the three M6 caphead socket screws located in the base of rear housing.
- Remove rear housing by sliding down the cable.
- Place the end of the magnet with the black dot against the spot on the "Cal Mag" text on the sensor and re-apply the power to both the machinery and the Rotospeed. Continue to hold the magnet in position until the machinery has reached its correct running speed and then remove the magnet. The sensor will self-calibrate for 20% under the monitored speed and the output LED will flash at one second intervals, to confirm start up delay.
- To recalibrate the start up delay; with machinery running reapply the magnet to the "Cal Mag" Text on product label for a period equal to the required start up delay and then remove the magnet.

Note: Whilst the magnet is placed against the "Cal Mag" position the output LED will flash at one second intervals as a guide to time delay. When the magnet is removed the sensor will self calibrate to 20% under the monitored speed and then the output LED will again flash at one second intervals, to confirm the start up delay.

SPECIFICATIONS

Supply:	12-240v dc or 24-240v ac.	Output State:	Normally closed (Volt drop 6 volts max) above set speed. Normally open (leakage current 1.6mA max).
Fusing:	Supply to be fused at 5A max.	Trip Level:	20% below set speed.
Switching Capacity:	200mA max.	Relative Humidity:	90% RH
Saturation Voltage:	6 volts max (output on).	Start Up Delay:	0-30secs.
Ambeint Temp:	-25°C to +70°C.		

• HYGIENIC ROTARY VALVE - KLEAN LOK •

INTRODUCTION

The prime function of Rotary Valves is to regulate the flow of dust, powder and granular products from one chamber to another whilst maintaining a good airlock.

It is popularly used in pneumatic conveying systems, both vacuum and pressure, together with cyclone and filter applications.

However, the Klean Lok is a more specialist valve. Its modular design makes it an easy-clean valve, aimed specifically at the food, chemical and pharmaceutical industries, where cleanliness, both internally and externally, must be to a high standard.

KLEAN LOK

Rotolok manufactures a complete range of Rotary Valves and in the past, for hygienic applications, the standard range has been used, resulting in large costs being incurred to meet the food standards with regard to polishing etc.

The Klean Lok is, by design, a different concept as it has been styled to ensure that all internal and external surfaces can be fully machined, creating a smooth surface with no lodgement points. This minimises and simplifies polishing and enables the user to clean or wash the valve quickly and easily.

The drive is normally direct coupled, making the complete assembly more compact and eliminating the need for motor mounting plates and bosses, which significantly complicate the external cleaning operation.

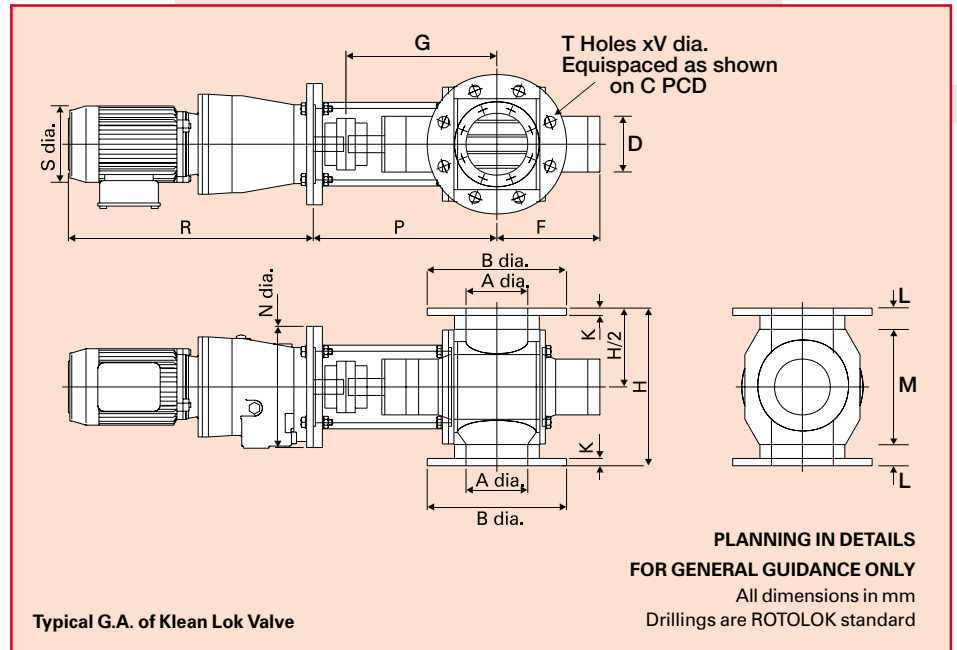

To facilitate the internal cleaning of the valve the rotor is available Quick Release.

RANGE

All Klean Loks are constructed from cast stainless steel with stainless steel rotors, to meet hygiene requirements. Standard range sizes, 100mm to 250mm diameter, but this will be extended to customer needs.

Range is being extended

On Quick Release Models 38mm is to be added to 'G' and 'P' dimensions.

Drive arrangement is for our Standard Helical Gear Flange Mounted Unit. Other Mounting Units e.g. Worm Boxes can be accommodated.

Ask for certified drawing.

IMPORTANT FEATURES

- Machined externals and internals.
- Compact design.
- No lodgement points.
- Quick release.
- Robust body and rotor.
- Outboard bearings for non-contamination.
- Modular design.

	A	B	C	D	F	G	H	K	L	M	N	P	R	S	T	V	CAPACITY CU FT/REV	K.W.
75	75	191	152	92	152	216	210	12	35	140	200	297	420	126	4	19	.02	.37
100	100	230	190	92	170	244	260	12	35	190	200	303	420	126	8	19	.08	.37
150	150	280	241	92	195	270	325	12	35	255	200	333	420	126	8	22	.23	.37
200	200	343	298	92	222	295	395	12	35	325	250	402	450	158	8	22	.50	.75
250	250	406	362	92	249	325	520	20	50	420	250	411	450	158	12	25	1.00	.75

Dimensions in millimetres unless stated

Dimension subject to change without notice