

Housed Easy Clean Grid

At A Glance



Protection: Secondary



Feed Type: Gravity



Material Type: NdFeb



Cleaning Type: Manual

Our high intensity magnetic easy clean housed grids offer unsurpassed levels of contamination removal, removing sub-micron ferrous and para-magnetic contamination from the most demanding and arduous of process environments.

The unit contains one high intensity easy clean magnetic grid. The grid is secured into the housing by tri-cone locking nuts which ensure even pressure is generated around the food grade seal.

It is common to have numerous units installed throughout a processing facility to ensure contamination is removed at source of generation. All dry powders and granular type materials can be processed through the unit. Electrical safety interlocks can be fitted to the grid to stop the process should it be accidentally opened.



Benefits

- Easy to clean
- Removes micron sized contaminants
- High collection capacity
- Reduces 'spark' risk

Performance

Magnetic Performance	7000, 9000, 10000
Performance Reading	On tube surface
Magnet Grade	N35 & N45 – Inspected and confirmed via hysteresograph prior to use
Temperature	-20°C / +90°C
Pressure	+ / - 0.2 Bar

Suitability

Suitable Products	Dry powders and granulates
Suitable Location	Inlet / outlet points, pre- / post-silo and machinery points

Materials

Magnetic Material	Rare Earth Neodymium Iron Boron - (NdFeb)
Housing	316 grade stainless steel
Tubing	316 grade stainless steel
Sealing	Self adhered white foam
Tri-cone Nuts	Stainless Steel
Surface Finish	Brushed internally / Polished externally to 0.6µm

Cleaning

When the unit requires cleaning, simply remove the outer grid securing tri-cone locking nuts and remove the grid from the housing. Remove the central tri-cone locking nut and separate the grid assembly allowing all attracted contamination to simply fall away.

Options

- Stainless Steel Toggle Clamps
- Larger sizes available
- Pharmaceutical specification
- Safety relay switches
- Metal Detectable Seal
- Higher temperature versions available

Housed Easy Clean Grid – Single

Round

Square

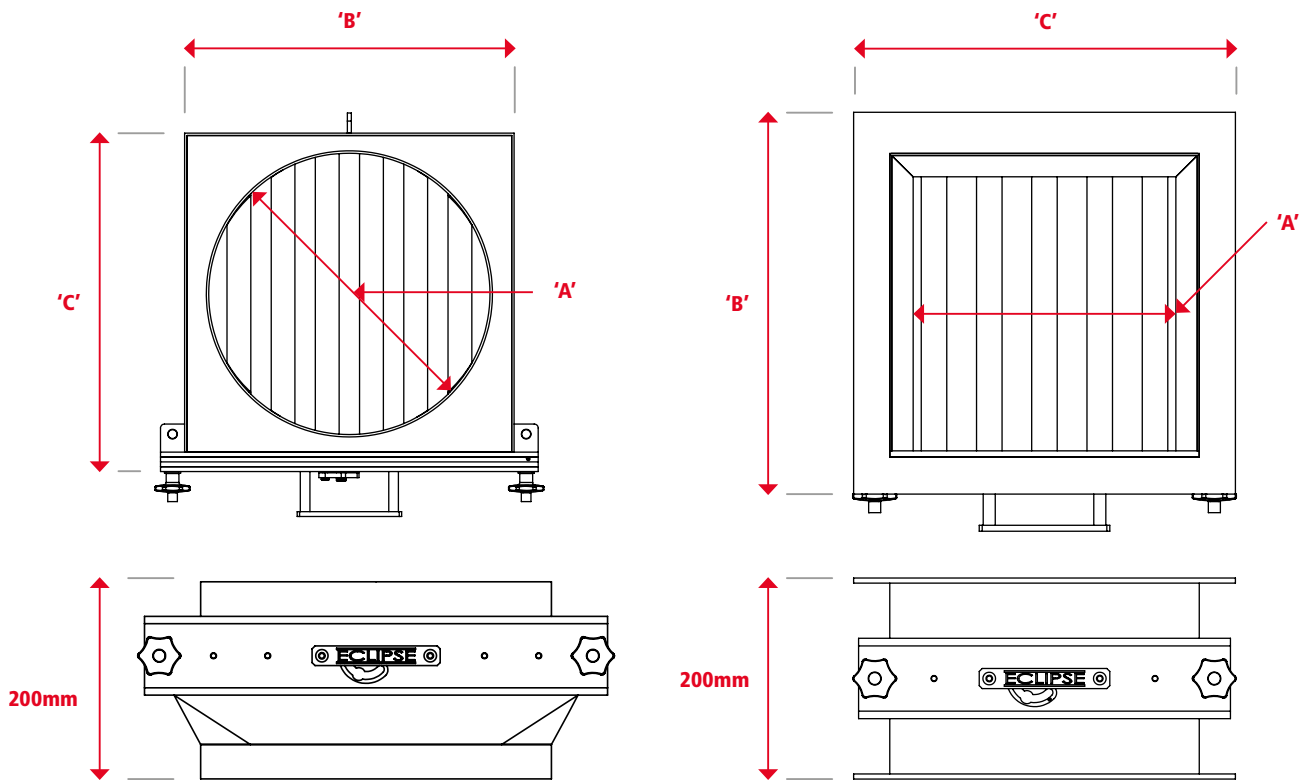

Part Number (Round)	A (mm)	B (mm)	C (mm)	Number Of Rods
ECHS100	100	158	168	2
ECHS150	150	208	218	3
ECHS200	200	258	268	4
ECHS250	250	308	318	5
ECHS300	300	358	368	6
ECHS350	350	408	418	7
ECHS400	400	460	470	8
ECHS450	450	510	520	9
ECHS500	500	560	570	10

Part Number (Square)	A (mm)	B (mm)	C (mm)	Number Of Rods
ECHS1515	150	230	230	2
ECHS2020	200	280	280	3
ECHS2525	250	330	330	4
ECHS3030	300	380	380	5
ECHS3535	350	430	430	6
ECHS4040	400	480	480	7
ECHS4545	450	530	530	8
ECHS5050	500	580	580	9

Other sizes available upon request

Housed Easy Clean Grid – Double

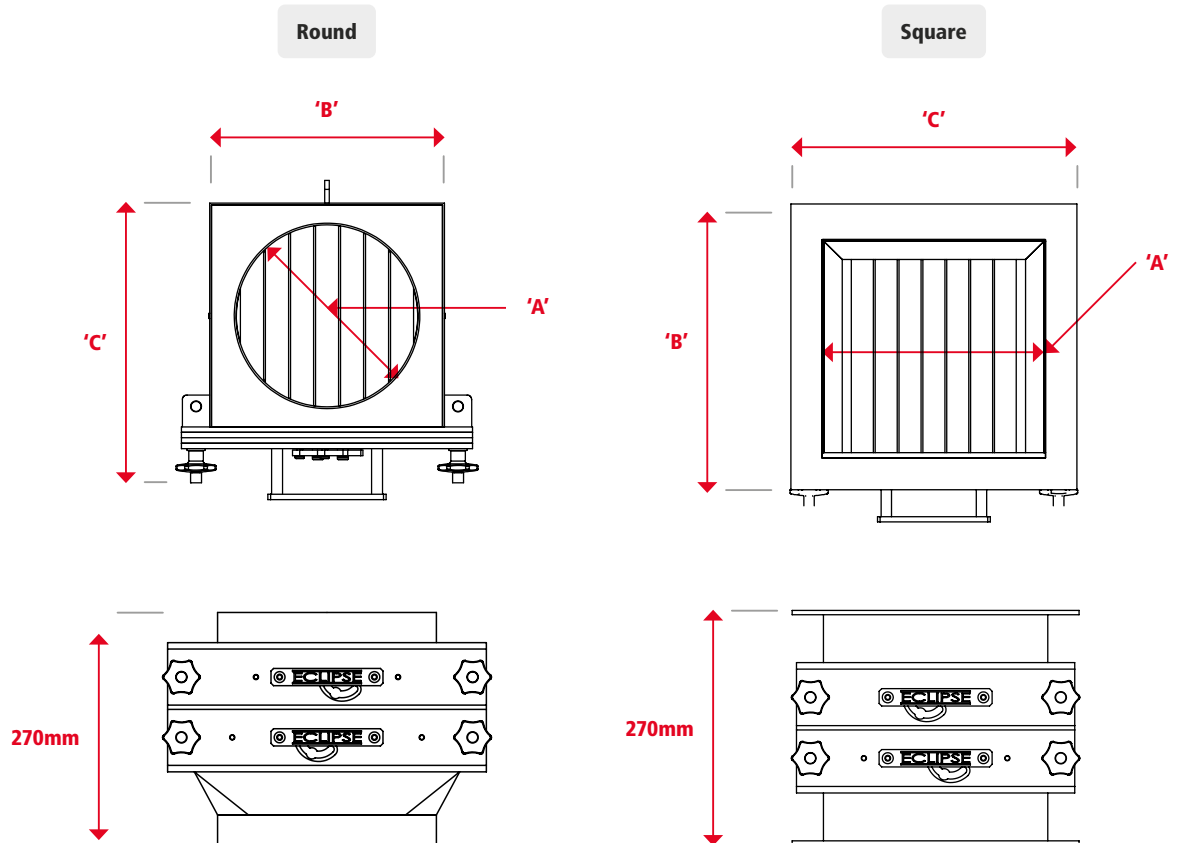

Part Number (Round)	A (mm)	B (mm)	C (mm)	Number Of Rods
ECHD100	100	158	168	1 + 2
ECHD150	150	208	218	2 + 3
ECHD200	200	258	268	3 + 4
ECHD250	250	308	318	4 + 5
ECHD300	300	358	368	5 + 6
ECHD350	350	408	418	6 + 7
ECHD400	400	458	470	7 + 8
ECHD450	450	508	520	8 + 9
ECHD500	500	558	570	9 + 10

Part Number (Square)	A (mm)	B (mm)	C (mm)	Number Of Rods
ECHD1515	150	230	230	2 + 1
ECHD2020	200	280	280	3 + 2
ECHD2525	250	330	330	5 + 3
ECHD3030	300	380	380	5 + 4
ECHD3535	350	430	430	6 + 5
ECHD4040	400	480	480	7 + 6
ECHD4545	450	530	530	8 + 9
ECHD5050	500	580	580	9 + 8

Other sizes available upon request

Housed Easy Clean Grid – Triple

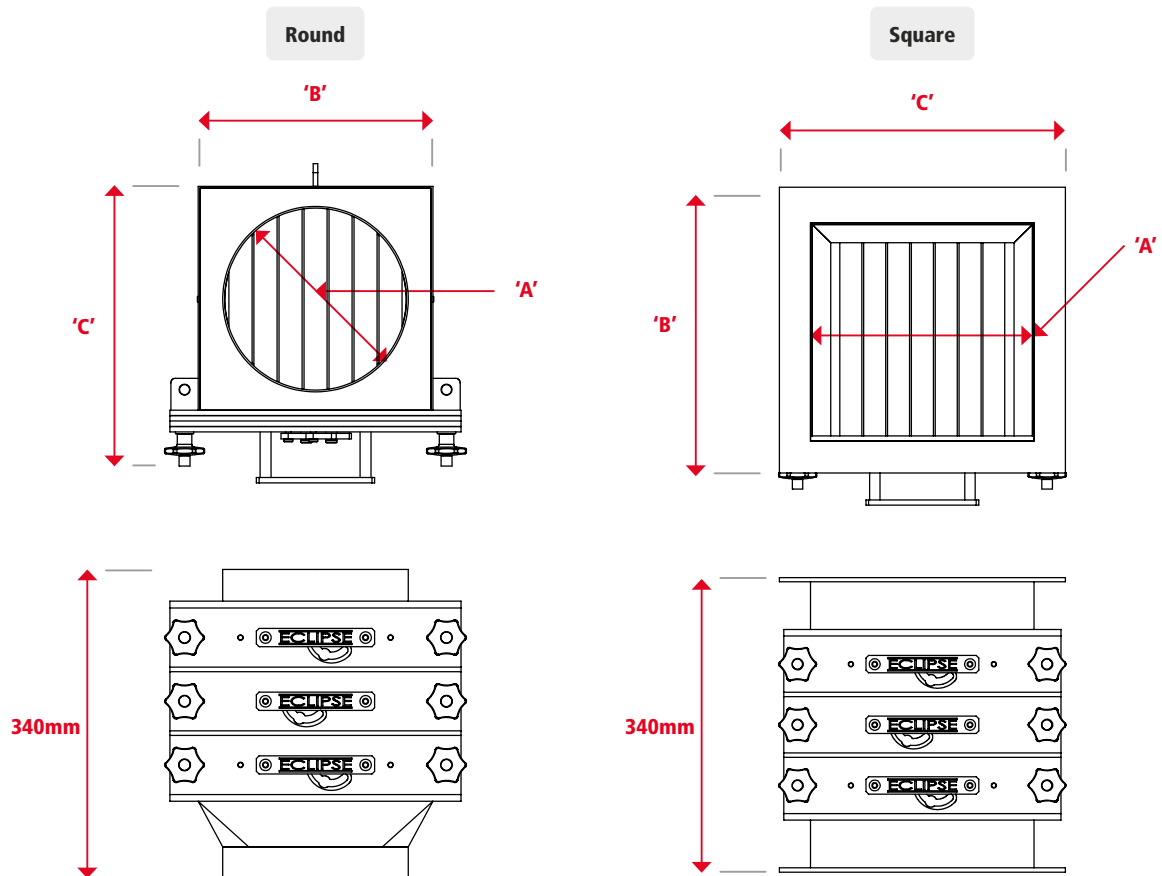

Part Number (Round)	A (mm)	B (mm)	C (mm)	Number Of Rods
ECHT100	100	160	171	1 + 2 + 1
ECHT150	150	210	221	2 + 3 + 2
ECHT200	200	260	271	3 + 4 + 3
ECHT250	250	310	321	4 + 5 + 4
ECHT300	300	360	371	5 + 6 + 5
ECHT350	350	410	421	6 + 7 + 6
ECHT400	400	460	471	7 + 8 + 7
ECHT450	450	510	521	8 + 9 + 8
ECHT500	500	560	571	9 + 10 + 9

Part Number (Square)	A (mm)	B (mm)	C (mm)	Number Of Rods
ECHT1515	150	230	230	1 + 2 + 1
ECHT2020	200	280	280	2 + 3 + 2
ECHT2525	250	330	330	3 + 4 + 3
ECHT3030	300	380	380	4 + 5 + 4
ECHT3535	350	430	430	5 + 6 + 5
ECHT4040	400	480	480	6 + 7 + 6
ECHT4545	450	530	530	7 + 8 + 7
ECHT5050	500	580	580	8 + 9 + 8

Other sizes available upon request

Housed Easy Clean Grid – Quadruple

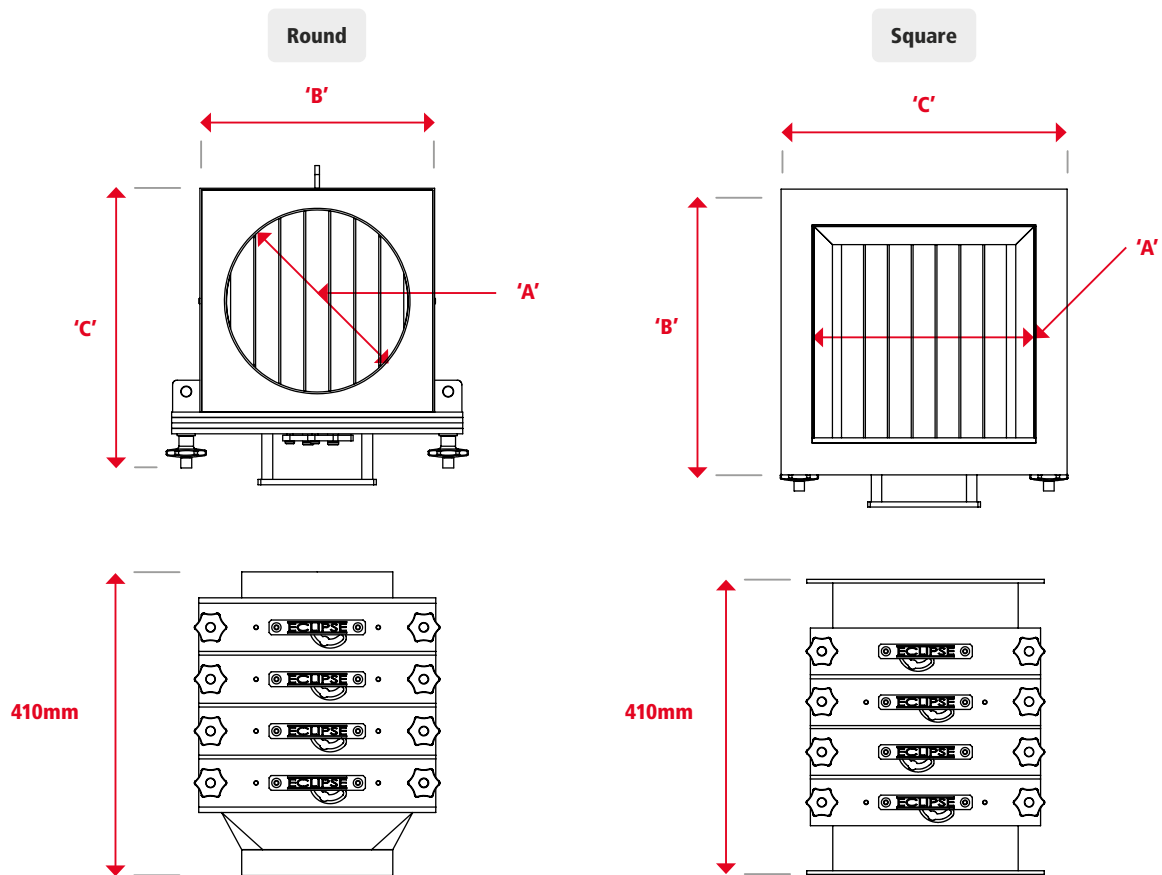

Part Number (Round)	A (mm)	B (mm)	C (mm)	Number Of Rods
ECHQ100	100	160	171	1 + 2 + 1 + 2
ECHQ150	150	210	221	2 + 3 + 2 + 3
ECHQ200	200	260	271	3 + 4 + 3 + 4
ECHQ250	250	310	321	4 + 5 + 4 + 5
ECHQ300	300	360	371	5 + 6 + 5 + 6
ECHQ350	350	410	421	6 + 7 + 6 + 7
ECHQ400	400	460	471	7 + 8 + 7 + 8
ECHQ450	450	510	521	8 + 9 + 8 + 9
ECHQ500	500	560	571	9 + 10 + 9 + 10

Part Number (Square)	A (mm)	B (mm)	C (mm)	Number Of Rods
ECHQ1515	150	230	230	1 + 2 + 1 + 2
ECHQ2020	200	280	280	2 + 3 + 2 + 3
ECHQ2525	250	330	330	3 + 4 + 3 + 4
ECHQ3030	300	380	380	4 + 5 + 4 + 5
ECHQ3535	350	430	430	5 + 6 + 5 + 6
ECHQ4040	400	480	480	6 + 7 + 6 + 7
ECHQ4545	450	530	530	7 + 8 + 7 + 8
ECHQ5050	500	580	580	8 + 9 + 8 + 9

Other sizes available upon request